

**Warning, Offer of Sale**

---

** WARNING**

FAILURE OR IMPROPER SELECTION OR IMPROPER USE OF THE PRODUCTS AND/OR SYSTEMS DESCRIBED HEREIN OR RELATED ITEMS CAN CAUSE DEATH, PERSONAL INJURY AND PROPERTY DAMAGE.

This document and other information from Parker Hannifin Corporation, its subsidiaries and authorized distributors provide product and/or system options for further investigation by users having technical expertise. It is important that you analyze all aspects of your application including consequences of any failure, and review the information concerning the product or system in the current product catalog. Due to the variety of operating conditions and applications for these products or systems, the user, through its own analysis and testing, is solely responsible for making the final selection of the products and systems and assuring that all performance, safety and warning requirements of the application are met.

The products described herein, including without limitation, product features, specifications, designs, availability and pricing, are subject to change by Parker Hannifin Corporation and its subsidiaries at any time without notice.

**Offer of Sale**

The items described in this document are hereby offered for sale by Parker Hannifin Corporation, its subsidiaries or its authorized distributors. This offer and its acceptance are governed by the provisions stated on the separate page of this document entitled "Offer of Sale".

© Copyright 2011, 2008, 2001 Parker Hannifin Corporation. All Rights Reserved



**Table of Contents**

<b>QUBE Modular FRL System</b>	<b>A</b> QUBE Modular FRL System
<b>Air Preparation Units</b>	<b>B</b> Air Preparation Units
<b>Precision and Proportional Regulators</b>	<b>C</b> Precision & Proportional Regulators
<b>Miniature FRL's</b>	<b>D</b> Miniature FRLs
<b>Stainless Steel FRL's</b>	<b>E</b> Stainless Steel FRLs
<b>Control Panel Products</b>	<b>F</b> Control Panels
<b>LV / EZ Lockout Valves</b>	<b>G</b> LV / EZ Lockout Valves
<b>Integrated Fittings</b>	<b>H</b> Integrated Fittings
<b>Accessories</b>	<b>J</b> Accessories
<b>Ball Valves / Plug Valves</b>	<b>K</b> Ball Valves / Plug Valves
<b>Quick Couplings</b>	<b>L</b> Quick Couplings
<b>Hose &amp; Fittings</b>	<b>M</b> Hose & Fittings
<b>Tubing &amp; Fittings</b>	<b>N</b> Tubing & Fittings
<b>Safety Guide, Offer of Sale</b>	<b>P</b> Safety Guide, Offer of Sale

## Section J



J

Tank Valves & Air Chucks.....	J2	Muffler-Reclassifier ECS .....	J7
EM Series Exhaust Mufflers.....	J3	Automatic Drip Leg Drain & Relief Valve.....	J8
Muffler / Flow Controls .....	J3	Relief Valves - Diaphragm Type.....	J9
Breather Vents.....	J4	Shuttle Valves & Quick Exhaust .....	J10-J12
ES Series Silencer .....	J4	AirGuard System .....	J13-J14
ASN Air Line Silencer.....	J5	Drain Valves.....	J15-J16
P6M Air Line Silencer .....	J6	Safety Blow Guns.....	J17-J18

**Tank Valves**

For tanks, steel barrels, compressors and other pneumatic containers where a dependable automatic air valve is needed. Equipped with standard valve core and sealing cap. Maximum operating pressure is 185 PSIG. Temperature range is -40°F to 220°F.

**Model No. 09166 0060**

Has a 1/8" pipe thread at bottom for minimum protrusion. N/P finish, dome shaped cap. Packed 25 to a box.

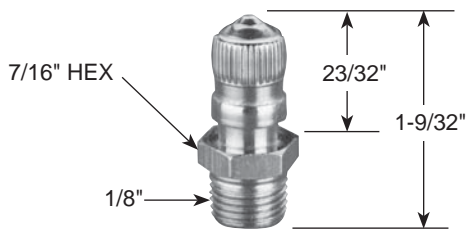

**Air Chucks**

For regular airlines.

**Model No. 05499 0000**

Ball-foot air chuck, 1/4" female port. Packed 10 to a box.



**Model No. 00645 0060**

A 1/8" pipe thread at bottom permits maximum protrusion. N/P finish, screwdriver type cap. Packed 25 to a box.

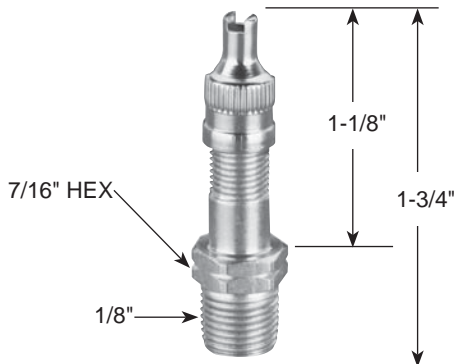

**Model No. 06739 0000**

Ball-foot air chuck with clip. Fits standard valve mouth. Saves holding on by hand. Has 1/4" port for connecting to hose. Packed 10 to a box.



**Model No. 01468 0006**

Has a 1/8" pipe thread part way up the stem which allows for minimum protrusion. N/P finish, has screwdriver type cap. Packed 25 to a box.

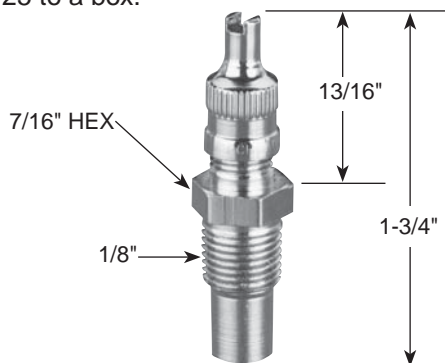

J

## EM Series – Sintered Bronze Muffler / Filters

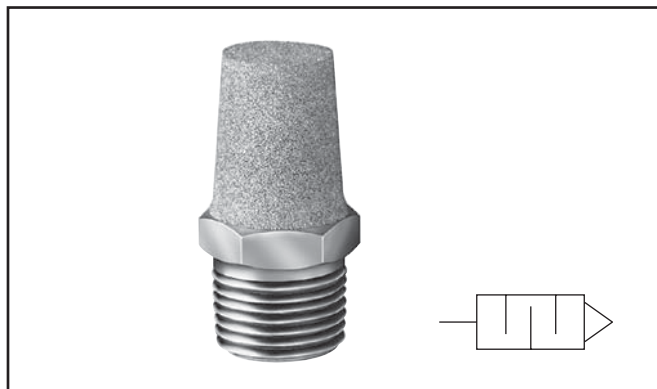

### General Description

Muffler / filters effectively reduce air exhaust noises to an industry accepted level with minimum flow restriction. They protect valves, impact wrenches, screw drivers and other air tools by preventing dirt and other foreign matter from entering the system. Non-corrosive. Can be cleaned with many common solvents.

### Specifications

**Maximum Operating Pressure**.....250 PSIG (Air)

**Operating Temperature** ..... 0° to 300°F\*

\* Ambient temperatures below freezing require moisture-free air. Ambient temperatures below freezing and above 180° require lubricants especially selected for suitability at these temperatures. Pneumatic valves should be used with filtered and lubricated air.

Model Number	Pipe Thread	Overall Length	Hex Size
EM12	1/8"	1.00	7/16"
EM25	1/4"	1.32	9/16"
EM37	3/8"	1.54	11/16"
EM50	1/2"	1.85	7/8"
EM75	3/4"	2.29	1-1/6"
EM100	1"	2.91	1-5/16"
EM125	1-1/4"	3.25	1-11/16"
EM150	1-1/2"	3.69	2"

## Muffler / Flow Controls



### General Description

Muffler / flow controls provide an acceptable exhaust noise level and effectively meter exhaust. Installed in valve exhaust ports, they control cylinder piston speeds throughout a wide range. The adjusting screw cannot be accidentally blown out, can be locked to maintain setting. Brass and bronze construction. Clean with commonly used solvents.

### Specifications

**Maximum Operating Pressure**.....250 PSIG (Air)

**Operating Temperature** ..... 0° to 300°F\*

\* Ambient temperatures below freezing require moisture-free air. Ambient temperatures below freezing and above 180° require lubricants especially selected for suitability at these temperatures. Pneumatic valves should be used with filtered and lubricated air.

Model Number	Pipe Thread	Overall Length	Hex Size
04502 0002	1/8"	1.15	9/16"
04504 0004	1/4"	1.42	1/2"
04506 0060	3/8"	1.49	11/16"
04508 0080	1/2"	1.77	7/8"
04512 0012	3/4"	1.98	1-1/16"
04516 0016	1"	2.15	1-5/16"



**Breather Vents**

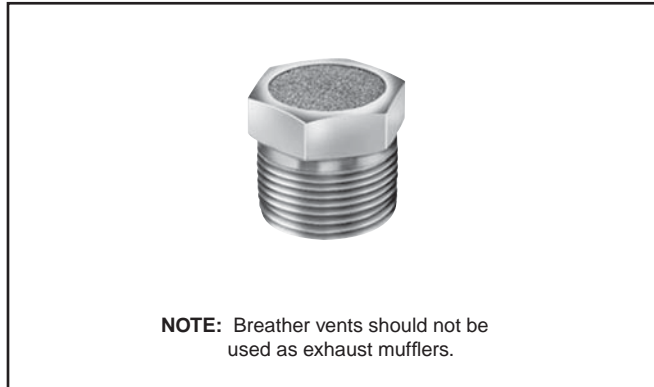

**General Description**

These low silhouette versions of the muffler / filter are useful where space is a problem and / or to prevent contamination. Use for vacuum relief or pressure equalization in gear boxes, oil tanks, reservoirs, etc. Non-corrosive.

**Specifications**

**Maximum Operating Pressure**..... 150 PSIG (Air)

**Operating Temperature** ..... 0° to 300°F\*

\* Ambient temperatures below freezing require moisture-free air. Ambient temperatures below freezing and above 180° require lubricants especially selected for suitability at these temperatures. Pneumatic valves should be used with filtered and lubricated air.

Model Number	Pipe Thread	Overall Length	Hex Size
04702 0002	1/8"	0.44	7/16"
04704 0004	1/4"	0.63	9/16"
04706 0006	3/8"	0.75	11/16"
04708 0008	1/2"	0.88	7/8"
04712 0012	3/4"	1.00	1-1/6"
04716 0016	1"	1.31	1-5/16"
04720 0020	1-1/4"	1.41	1-11/16"
04724 0024	1-1/2"	1.50	2"

**ES Series – Silencer**

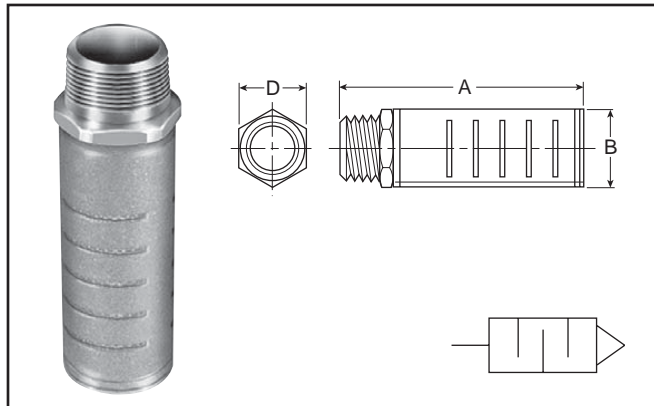

**General Description**

These low silhouette versions of the muffler / filter are useful where space is a problem and / or to prevent contamination. Use for vacuum relief or pressure equalization in gear boxes, oil tanks, reservoirs, etc. Non-corrosive.

The silencer is designed to give superior performance in noise control with a minimum effect on air efficiency. "Trimline" design allows location in the tightest places without extra plumbing and fittings. Fits directly into the exhaust port of more than 90% of present commercial valves. Slotted body permits rapid discharge of air without undesirable back pressure. Unique nylon screen element resists dirt buildup or clogging.

**Specifications**

**Maximum Operating Pressure**.....250 PSIG (Air)

**Operating Temperature** ..... 0° to 300°F\*

\* Ambient temperatures below freezing require moisture-free air. Ambient temperatures below freezing and above 180° require lubricants especially selected for suitability at these temperatures. Pneumatic valves should be used with filtered and lubricated air.

Model Numbers		Pipe Thread	Flow SCFM @ 100 PSIG Inlet	Dimensions		
NPTF	BSPT (R)			A	B	D
ES12MC	ESB12MC	1/8"	115	1.85	0.81	0.63
ES25MC	ESB25MC	1/4"	129	1.85	0.81	0.63
ES37MC	ESB37MC	3/8"	219	3.31	1.26	1.00
ES50MC	ESB50MC	1/2"	549	3.31	1.26	1.00
ES75MC	ESB75MC	3/4"	893	4.56	2.01	1.62
ES100MC	ESB100MC	1"	1,013	4.56	2.01	1.62
ES125MC	ESB125MC	1-1/4"	1,486	5.69	2.88	—
ES150MC	ESB150MC	1-1/2"	1,580	5.69	2.88	—

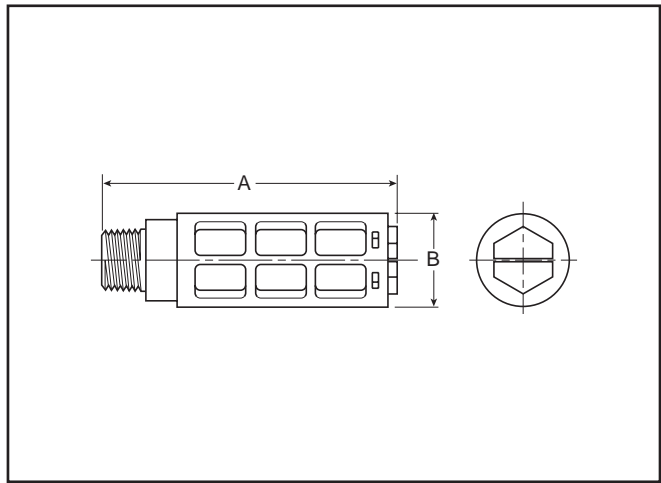
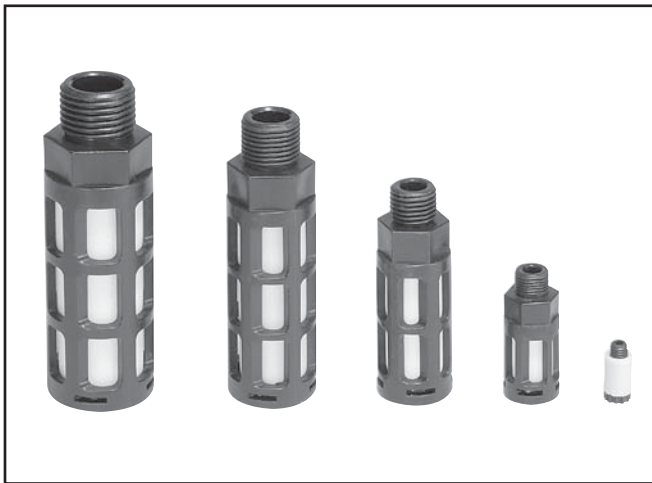

**Features**

- Compact
- Lightweight
- Easy to Install
- Excellent Noise Reduction
- Protects Components from Contamination
- NPT and BSPT Threads Available

Part Number		Thread Size	A (mm)	B (mm)	Maximum Flow (SCFM) 100 PSIG Inlet	Sound Pressure Level (dBA)	
NPT	BSPT					20 PSIG Inlet	100 PSIG Inlet
AS-5		M5	0.43 (11)	0.32 (8)	15	69	79
ASN-6	AS-6	1/8"	1.57 (40)	0.63 (16)	51	69	81
ASN-8	AS-8	1/4"	2.56 (65)	0.83 (21)	124	67	84
ASN-10	AS-10	3/8"	3.35 (85)	0.98 (25)	247	83	98
ASN-15	AS-15	1/2"	3.74 (95)	1.18 (30)	370	69	96

**Application**

The plastic silencer is designed to give excellent noise reduction with a minimum effect on air efficiency. The "Trimline" design allows for locating the silencer in the tightest places without extra plumbing or fittings. Fits directly into the exhaust port of most commercial valves. Open surface area of element allows for rapid discharge of air without undesirable back pressure.

**Specifications**

**Pressure Rating**.....0 to 150 PSIG  
(0 to 10 bar, 0 to 1034 kPa)

**Temperature Rating** ..... 14°F to 140°F (-10°C to 60°C)

**Body** .....Acetal (Plastic)

**Element** ..... Polyethylene



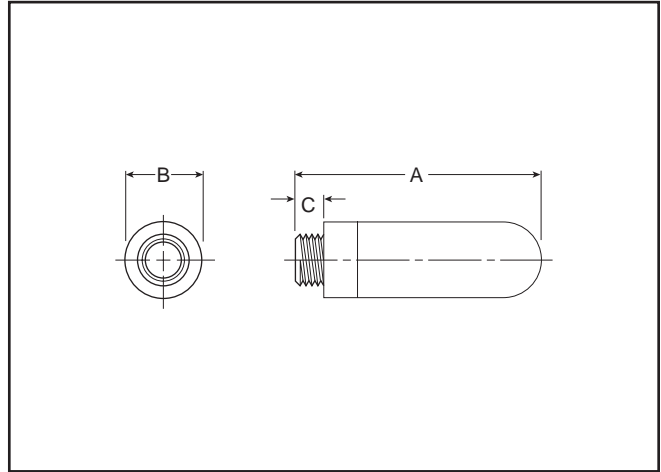
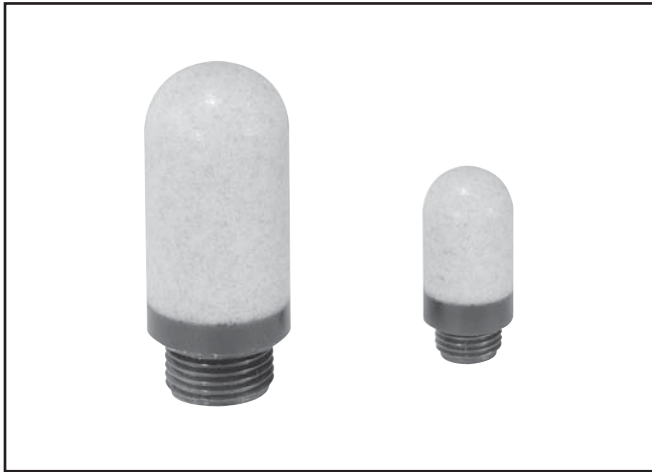

**Features**

- All Plastic Ultra Light Weight Versions
- High Noise Level Reduction
- Low Back Pressure Generation

**Application**

The plastic silencer is designed to give excellent noise reduction with a minimum effect on air efficiency. The “Trimline” design allows for locating the silencer in the tightest places without extra plumbing or fittings. Fits directly into the exhaust port of most commercial valves. Open surface area of element allows for rapid discharge of air without undesirable back pressure.

Part Number	Port Thread	A	Diameter B	C	Weight (grams)
P6M-PAC5	M5	0.91 (23)	0.26 (6,5)	0.16 (4)	0.01
P6M-PAB1	G1/8	1.14 (29)	0.55 (14)	0.24 (6)	0.02
P6M-PAB2	G1/4	1.34 (34)	0.67 (17)	0.24 (6)	0.04
P6M-PAB3	G3/8	2.36 (60)	0.98 (25)	0.35 (9)	0.06
P6M-PAB4	G1/2	2.52 (64)	0.98 (25)	0.43 (11)	0.10
P6M-PAB6	G3/4	5.51 (140)	1.50 (38)	0.55 (14)	0.50
P6M-PAB8	G1	6.30 (160)	1.89 (48)	0.79 (20)	0.62



**Specifications**

Pressure Rating..... 0 to 246 PSIG  
(0 to 17 bar, 0 to 1700 kPa)

**Temperature Rating**

Plastic ..... 14°F to 176 °F (-10°C to 80°C)  
 Metal..... 14°F to 165 °F (-10°C to 74°C)  
 Efficiency .....92%

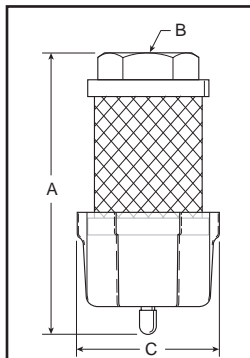

**Dimensions:**

Model	A	B	C
ECS3	5.30 (135 mm)	1/2" NPT	2.57 (65 mm)
ECS5	7.30 (185mm)	1" NPT	2.57 (65mm)

**Operation**

Compressor oils and lubricating oils are exhausted from valves, cylinders and air motors into the ECS. Oil aerosols are "coalesced" into larger droplets and gravity pulls them into the attached drain sump. The sump can then be drained manually or by using a 1/4" ID plastic tube drain. The air flowing into the ECS is also muffled or silenced as it enters the inside of the ECS and passes through the filter media into the atmosphere.

**Proven Technology**

The ECS units are constructed from the same materials that go into our oil removal coalescing filter elements. The seamless design insures media uniformity and strength. This proven technology provides high coalescing efficiency with low pressure drop.

The filter media is supported by cylindrical perforated steel retainers both inside and out. These retainers, fully plated for excellent corrosion resistance, give the ECS units high rupture strength in either flow direction. These filters can also be used as high efficiency inlet or bypass filters for vacuum pumps, or breather elements to protect the air above critical process liquids.

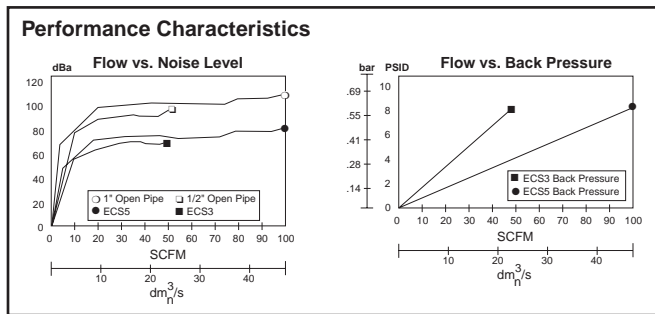

**Features**

The ECS (Muffler-Reclassifier) eliminates unwanted oil mist and reduces exhaust noise from pneumatic valves, cylinders and air motors.

- 99.97% Oil Removal Efficiencies
- 25 dBA Noise Attenuation
- 1/2" NPT and 1" NPT
- Disposable Units
- Continuous or Plugged Drain Option
- Metal Retained Construction
- Fast Exhaust Time

**Improve Overall Plant Environment**

Exhaust oil mist and noise pollution have a direct impact on worker productivity.

Oil aerosol mist from lubricators and compressors is pervasive and enters the industrial plant environment through the exhaust ports of valves, cylinders and air motors. This rapidly expanding exhaust also produces sudden and excessive noise.

The ECS (Muffler-Reclassifier) is 99.97% efficient at removing the oil aerosols. The ECS also acts as a silencer to lower the dBA levels below O.S.H.A. requirements.

The result is a cleaner, quieter environment which equates to greater work productivity and safety.

**ECS3 / ECS5**

The ECS solves two problems inherent in compressed air exhaust from valves, cylinders and air motors - oil mist removal and noise abatement.

The ECS will improve your industrial plant environment, thereby improving worker productivity.

**Specifications**

**Maximum Operating Temperature** ..... 125°F (52°C)  
**Maximum Line Pressure**..... 100 PSIG (6.8 bar)

**Ordering Information**

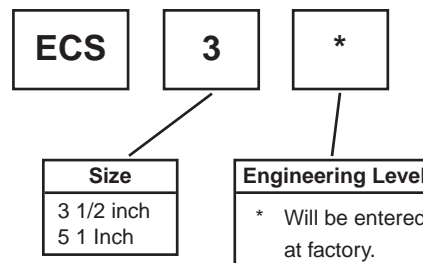

## Automatic Drip Leg Drain

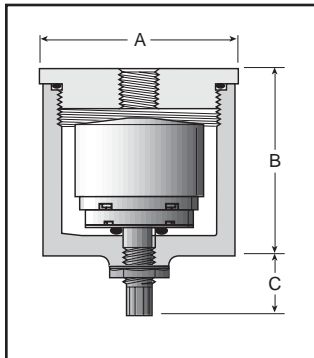

A	B	C
2.50	2.37	0.87
64 mm	60 mm	22 mm

### Features

- Auto Drain Ported 1/8" to Pipe Away Liquid.
- Drain has Manual Override
- Easily Serviced without Tool
- 20-250 PSIG Range
- Compact Size

### Specifications

Housing & Cap..... Aluminum  
 Port Threads ..... 1/4" - 1/2" Top  
 1/8" Drain

#### Pressure and Temperature Ratings:

Metal Bowl..... 20 to 250 PSIG (0 to 17.2 bar)  
 32°F to 175°F (0°C to 80°C)

Seals ..... Buna N

### Ordering Information

Consists of Drip Leg Drain Housing WITH Auto Drain.

Model No.	Size
06D1NA	1/4"
06D3NA	1/2"

## Relief Valve

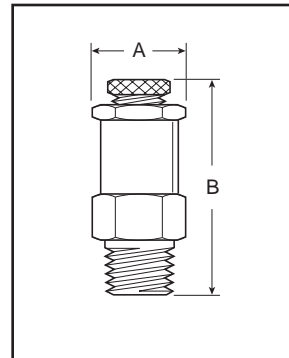
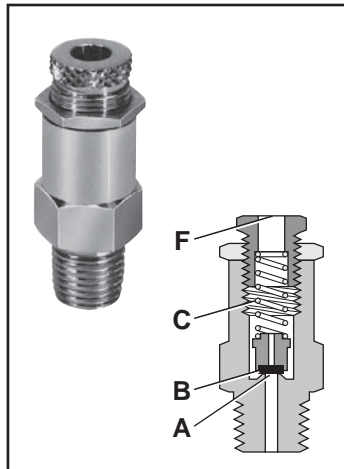

A	B
0.75 Hex	1.88 - 2.25
19 mm	47.8 - 57.2 mm

### Features

- Large Relief Capacity (70.39 SCFM @ 150 PSI when fully opened) in a Compact Size
- Lightweight Aluminum Construction with Resilient Seat

### Application

The RV01A1N Pop Off Relief Valve is designed to protect against excessive pressure buildup in a pneumatic circuit or system.

### Operation\*

With the relief valve mounted in a reservoir or system, the force of system pressure at (A) is offset by the force of spring (C) acting on poppet seat (B). At pressures lower than the setting, the poppet seat (B) is held against the body at (A) effecting a seal. As pressure approaches set point, the poppet begins to vent until set point is reached, at which time the poppet seat (B) lifts off the body at (A) allowing the excess pressure to vent to atmosphere at (F). When the excess pressure has been vented, the spring (C) acts on the poppet seat (B) forcing it to seat on the body at (A), sealing off the flow of air.

### Specification

Body & Adjusting Screw ..... Aluminum  
 Locking Nut ..... Steel  
 Seat..... Nitrile  
 Spring ..... Steel  
 Poppet ..... Plastic  
 Operating Temperature ..... 32°F to 200°F (0°C to 93°C)  
 Port Threads ..... 1/4 Inch Male  
 Relief Range ..... 10 to 200 PSIG (.7 to 14 bar)  
 with standard spring.

\* Ref: 1RV100B Installation & Service Instructions

### Ordering Information

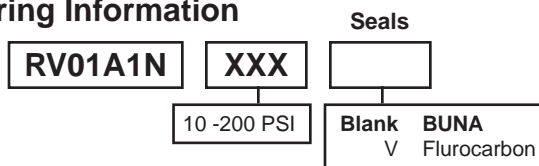

J

### 130 Relief Valve

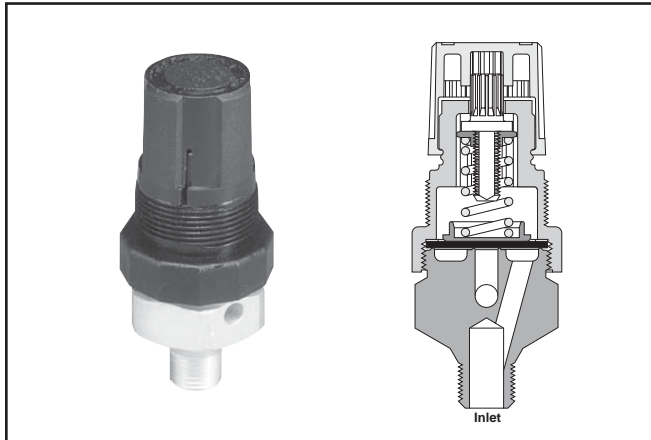

#### Features

- Compact, Sensitive Diaphragm-type Relief Valve
- Push-pull, Locking Knob
- Knob and Top Work the Same as a Miniature Regulator
- 130 has Lightweight Aluminum Construction
- 134 has a brass body, captured exhaust and is an Inline Type with 3 Inlet Ports and 1 Outlet Port

#### Applications

- Designed to Protect Against Excessive Pressure Buildup in a Pneumatic Circuit or System
- For Use where Gradual Proportional Relief is Required

#### Operation

- Turn relief valve knob clockwise for maximum pressure.
- Set pressure going into relief valve at desired pressure.
- Turn relief valve knob counter-clockwise until exhaust starts to bleed.
- Turn relief valve knob clockwise until exhaust stops bleeding. Push to lock knob.

#### Ordering Information

Relief Valve	Spring Range			
	0-15 PSIG	0-25 PSIG	0-50 PSIG	0-100 PSIG
130	130-02AA	130-02A	130-02B	130-02C
	130-02AAP*	130-02AP*	130-02BP*	130-02CP*
134	134-02AA	134-02A	134-02B	134-02C
	134-02AAP*	134-02AP*	134-02BP*	134-02CP*

\* Panel mount nut included.

### 134 Relief Valve

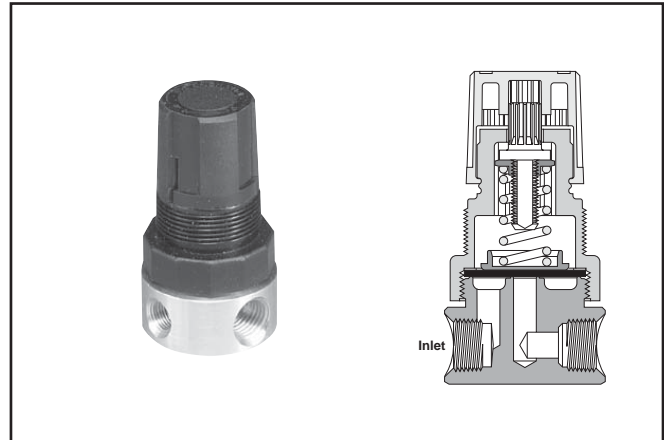

#### Dimensions

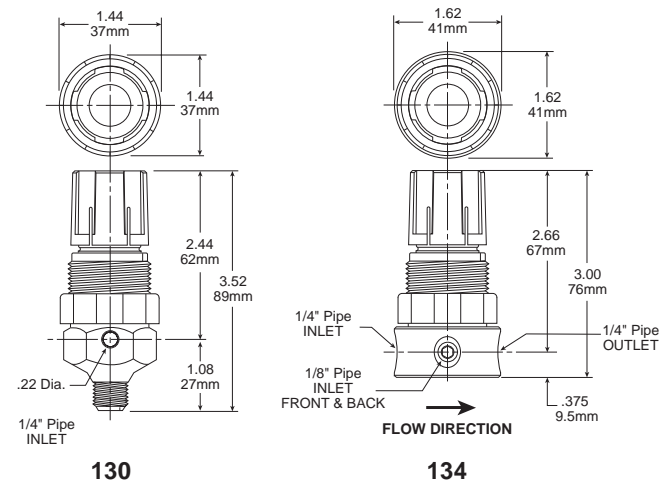

#### Relief Valve Kits

- Bonnet Assembly Kit .....PCKR364Y
- Panel Mount Nut .....PR05X51

#### Specifications

- Relief Range .....0 to 100 PSIG (0 to 6.9 bar)
- Maximum Inlet Pressure .....300 PSIG (20.7 bar)
- Operating Temperature ..... 40°F to 120°F (4°C to 49°C)
- Port Threads:
  - 130 ..... 1/4" Pipe Male Only
  - 134 ..... Inlet Port – Two 1/8" & One 1/4" Pipe  
Outlet Port – 1/4" Pipe

#### Materials of Construction

- Adjusting Knob ..... Polypropylene
- Adjusting Screw .....Zinc-plated Steel
- Body ..... Aluminum (130); Brass (134)
- Diaphragm / Disc .....Buna-N
- Nut .....Chromated Steel
- Spring Cage ..... Acetal
- Spring .....Zinc-plated Steel



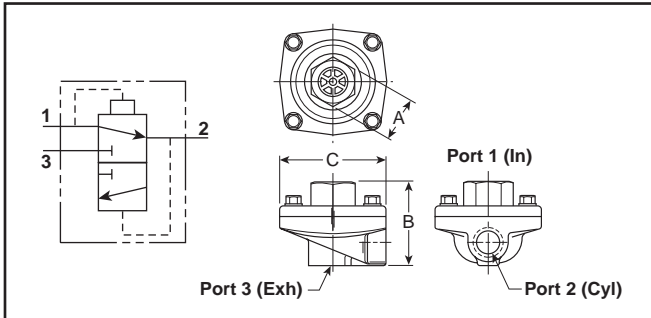
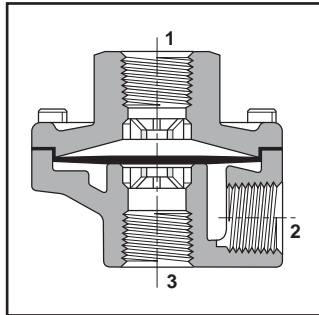
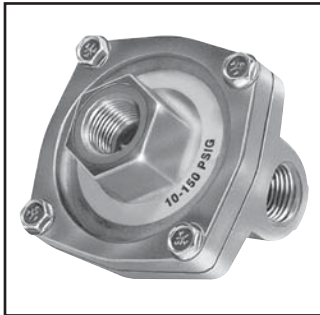

**Valve Specifications**

**Operating Pressure (Air)**

**Maximum:**

150 PSIG  
200 PSIG for Model No. 0R37TB (PTFE diaphragm)

**Minimum:**

3 PSIG  
50 PSIG for Model No. 0R37TB (PTFE diaphragm)

**Operating Temperature:**

Urethane: 0°F to 180°F\* (-18°C to 80°C)  
Nitrile: 0°F to 180°F\* (-18°C to 80°C)  
Fluorocarbon: 0°F to 400°F\* (-18°C to 205°C)  
PTFE: 0°F to 500°F\* (-18°C to 260°C)

\* Ambient temperatures below freezing require moisture-free air.  
Ambient temperatures below freezing and above 180° require lubricants especially selected for suitability at these temperatures.  
Pneumatic valves should be used with filtered and lubricated air.

**Component Materials**

**Body Material**..... Die cast aluminum

**Static Seals**.....Nitrile standard with urethane  
(Others see below)

**Diaphragm** ..... Standard – Urethane  
Optional – Fluorocarbon, PTFE, or Nitrile  
(Depending on size)

**General Information**

Quick exhaust valves provide rapid exhaust of control air when placed between control valve and actuator. They can also be used as shuttle valves. Diaphragm materials are available in urethane, Nitrile, Fluorocarbon, and PTFE to meet a wide variety of operating conditions.

**Mounting Bracket Kit –**

**No. 03640 8100**

(Including body screws)

For "0R12" and "0R25" sizes  
with 7/8" "A" Dimension.

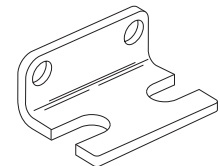

**Model Selection, Performance Data and Dimensions**

Port			Flow (SCFM)†	Model Number		A	B	C	Service Kit No.
1	2	3		NPTF	BSPP "G"				
<b>STANDARD URETHANE DIAPHRAGMS (Nitrile static seals)</b>									
1/4"	1/4"	3/8"	150	<b>0R25NB</b>	0RB25NB	1" Hex	2.06	2.44	03340 0105
	3/8"	3/8"	240	<b>0R25PB</b>	—	1" Hex	2.06	2.44	03340 0105
3/8"	3/8"	3/8"	240	<b>0R37B</b>	0RB37B	1" Hex	2.06	2.44	03340 0105
1/2"	1/2"	1/2"	450	<b>0R50B</b>	0RB50B	1-1/2" Hex	2.88	3.38	03475 0109
3/4"	3/4"	3/4"	550	<b>0R75B</b>	0RB75B	1-1/2" Hex	2.88	3.38	03475 0109
<b>NITRILE DIAPHRAGMS (Nitrile static seals)</b>									
1/8"	1/8"	1/8"	70	<b>0R12B</b>	0RB12B	7/8" Sq.	1.75	1.88	03640 8000
	1/8"	1/4"	70	<b>0R12NB</b>	0RB12NB	7/8" Sq.	1.75	1.88	03640 8000
1/4"	1/4"	1/4"	90	<b>0R25B</b>	0RB25B	7/8" Sq.	1.75	1.88	03640 8000
	1/4"	3/8"	90	<b>0R25NFB</b>	0RB25NFB	7/8" Sq.	1.75	1.88	03340 8000
3/8"	3/8"	3/8"	240	<b>0R37FB</b>	0RB37FB	1" Hex	2.06	2.44	03340 8000
3/4"	3/4"	3/4"	550	<b>0R75FB</b>	0RB75FB	1-1/2" Hex	2.88	3.38	03475 9000
<b>FLUOROCARBON DIAPHRAGMS for extended temperature operation (Fluorocarbon static seals)</b>									
1/8"	1/8"	1/8"	70	<b>0R12VB</b>	0RB12VB	7/8" Sq.	1.75	1.88	03650 8000
	1/8"	1/4"	70	<b>0R12NVB</b>	0RB12NVB	7/8" Sq.	1.75	1.88	03650 8000
1/4"	1/4"	1/4"	90	<b>0R25VB</b>	0RB25VB	7/8" Sq.	1.75	1.88	03650 8000
3/8"	3/8"	3/8"	240	<b>0R37VB</b>	0RB37VB	1" Hex	2.06	2.44	03340 0319
1/2"	1/2"	1/2"	450	<b>0R50VB</b>	0RB50VB	1-1/2" Hex	2.88	3.38	03475 0120
3/4"	3/4"	3/4"	550	<b>0R75VB</b>	0RB75VB	1-1/2" Hex	2.88	3.38	03475 0120
<b>PTFE DIAPHRAGMS for higher pressure and temperature (Fibre static seals)</b>									
3/8"	3/8"	3/8"	240	<b>0R37TB</b>	0RB37TB	1" Hex	2.06	2.44	03340 0504

† At 100 PSIG inlet pressure with full pressure drop.

**BOLD ITEMS ARE MOST POPULAR.**



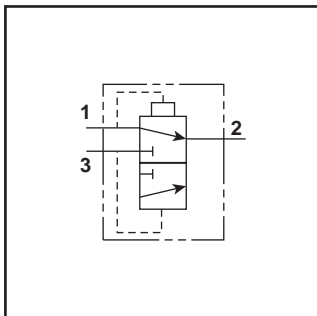
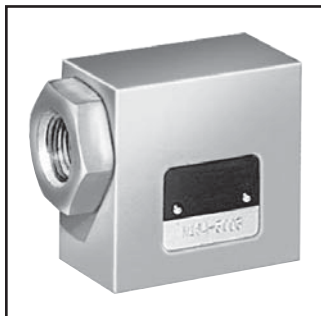

**General Information**

Shuttle valves determine a single pneumatic output from two separate inputs. If pressure is applied to both ports simultaneously, the valve will select the port with the higher pressure.

**Valve Specifications**

**Maximum Operating Pressure**.....200 PSIG Maximum  
 3 PSIG Minimum: Differential Pressure

**Operating Temperature** .....0° to 160°F\*

\* Ambient temperatures below freezing require moisture-free air. Ambient temperatures below freezing and above 180° require lubricants especially selected for suitability at these temperatures. Pneumatic valves should be used with filtered and lubricated air.

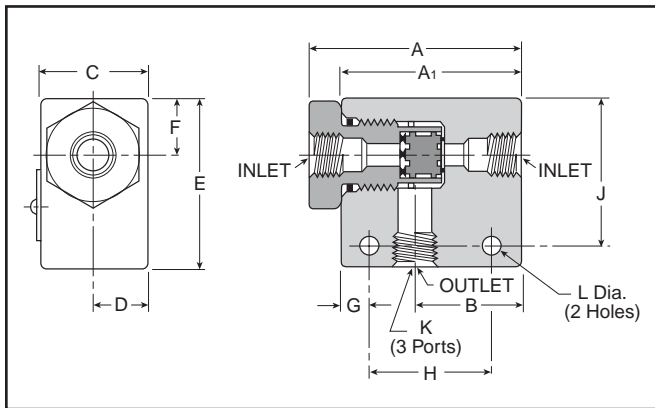

**Component Materials**

**Body Material**..... Aluminum  
**Internal Components**..... Aluminum  
**Seals**.....Nitrile

**Model Selection and Dimensions**

Model Number	Port Size	Dimensions											
		A	A1	B	C	D	E	F	G	H	J	K	L
<b>N164 1001</b>	1/8"	N/A	1.62	0.81	0.62	0.31	1.00	0.281	0.312	1.00	0.75	1/8 - 27	0.219
<b>N164 2003</b>	1/4"	2.50	2.12	1.25	1.25	0.62	2.00	0.67	0.265	1.25	1.35	1/4 - 18	0.219
<b>N164 3003</b>	3/8"	2.50	2.12	1.25	1.25	0.62	2.00	0.67	0.265	1.25	1.35	3/8 - 16	0.219

**Performance Data – Flow**

Model Number	Port Size	Flow (Cv)
<b>N164 1001</b>	1/8"	0.32
<b>N164 2003</b>	1/4"	1.65
<b>N164 3003</b>	3/8"	2.02



## Typical “Quick Exhaust Valve” Applications

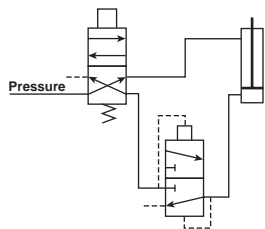

### Rapid Retraction – Double Acting Cylinder

In this circuit, air is exhausted through a Quick Exhaust Valve that is **close coupled** to the cap end of the cylinder. Because the Quick Exhaust Valve has a greater exhaust capacity than the four-way Control Valve, increased cylinder speed can be accomplished with a smaller and less expensive control valve.

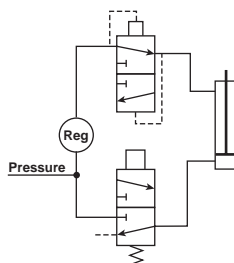

### Dual Pressure Actuation of Double Acting Cylinder

This circuit utilizes a Quick Exhaust Valve and a three-way Control Valve to permit rapid extension of the cylinder at a high pressure. Under life.

**NOTE:** Line pressure must be 3 or 4 times greater than rod end pressure. Effective working pressure is the differential between the cap and rod end.

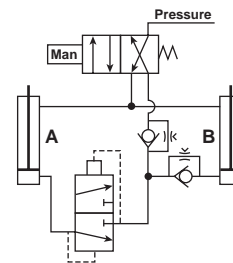

### Bi-Directional Control of Two Double Acting Cylinders

This circuit provides maximum control with a minimum of valving. A large four-way Control Valve is not needed to permit the rapid retraction of Cylinder A, as the Quick Exhaust Valve performs this function. The extension of Cylinders A and B and retraction of Cylinder B are controlled by Speed Control Valves.

## Typical “Shuttle Valve” Applications

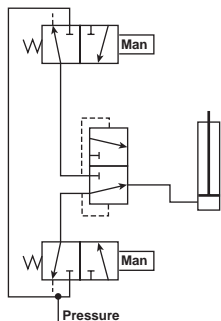

### “OR” Circuit

The most common application of the Shuttle Valve is the “OR” Circuit. Here a cylinder or other work device can be actuated by either control valve. The valves can be manually or electrically actuated and located in any position.

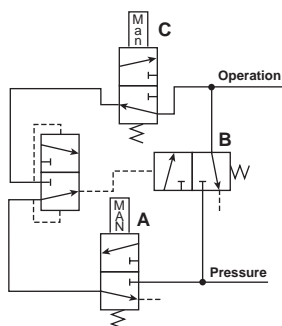

### Memory Circuit

This circuit enables continuous operation once initiated. Pressure is delivered to the circuit when Valve A is actuated. This allows pressure to pass through the shuttle valve actuating Valve B. Pressure then flows through Valve B and also the other side of the shuttle valve which holds Valve B open for continuous operation. To unlock the circuit, Valve C must be opened to exhaust the circuit and allow Valve B to return to its normally closed position.

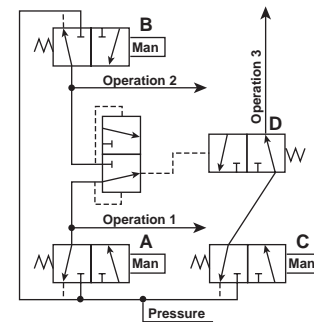

### Interlock

This circuit prevents the occurrence of a specific operation while one or another operation takes place. When either Valve A or B is actuated to perform operation 1 or 2, Valve D is shifted to the closed position and prevents operation 3 from occurring.

J

## AirGuard Protection System



### Product Features:

- **Maintenance Friendly**  
Repair possible while plant is still operating.
- **Economic**  
Competitive pricing.
- **Complies with EU Standard**  
EN 983 - § 5.3.4.3.2.
- **Reliable and Tamperproof**  
No adjustment necessary.
- **Complies with ISO Standard**  
4414 - § 5.4.5.11.1
- **Complies with MSHA Regulation**  
30CFR 56.13021, 57.13021 and 57.1730
- **Lightweight**  
Compact size.
- **Compatible with all Pneumatic Systems**
- **Can be used as a Flow Blocker**
- **TUV Approval**  
No. 01-02-0145
- **EU Registered Utility**  
Model No. 0025 73 525
- **Complies with OSHA Regulation Standard**  
29CFR 1926.302 (Partial)

### Protect your most important assets: your employees and their equipment!

The AirGuard offers simple but efficient protection of a broken compressed-air hose. The air supply is immediately shut off by the AirGuard, should the volume of air exceed a set value. This "value" is factory preset and is set to allow normal air consumption when using air tools.

Should the air consumption exceeds the set value, e.g. the air line is severed, then the internal piston instantly shuts off the main flow. An integral bleed hole allows some air to flow through. This enables the line pressure to automatically reset the AirGuard once the main line break is repaired.

### Function:

(P) is the inlet. Air passes the piston (1) and continues through the seat (3). The air flow, passing the piston, is slowed down by means of length wise grooves on the outer side of the piston. If the flow is too high, the air cannot pass the piston quickly enough, and the piston is forced against the spring (2) and towards the seat. The maximum flow is shown in the graph. If the value indicated is exceeded e.g. if the hose suddenly breaks - the air supply is automatically shut of. An integral bleed hole allows some air to flow through. This enables the line pressure to automatically reset the AirGuard once the main line break is repaired.

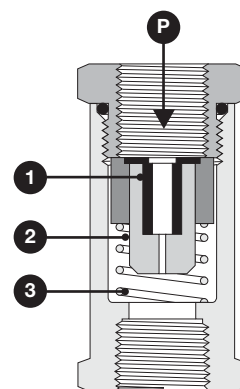

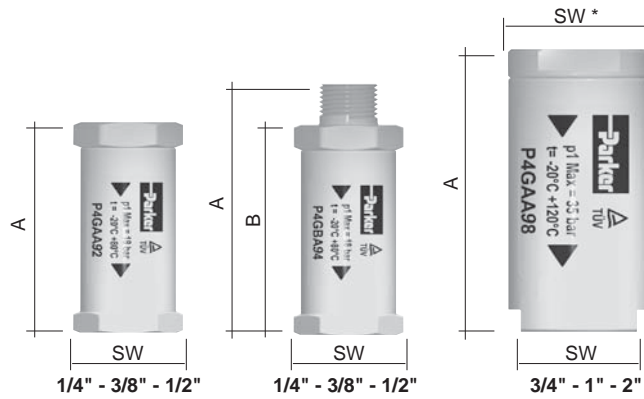

**Weight and Dimensions metric (imperial)**

Thread Connection	Dimensions mm (inch)			Weight g (oz.)	Max. Inlet Pressure	Temp. Range	Material	P1 Inlet Thread	P2 Outlet Thread	Part Number NPT	Part Number BSP				
	A	B	SW												
1/4"	48 (1.89)	-	22 (.87)	30 (1.06)	(18 bar) 255 PSIG	-20°C to 80°C (-4°F to 176°F)	Housing: Aluminum Piston: Polyacetal	Female	Female	P4GAA92	P4GAA12*				
1/4"	58 (2.28)	49 (1.93)	22 (.87)	36 (1.27)								Male	Female	P4GBA92	P4GBA12*
3/8"	59 (2.32)	-	28 (1.10)	58 (2.05)								Female	Female	P4GAA93	P4GAA13*
3/8"	71 (2.80)	59 (2.32)	28 (1.10)	62 (2.19)								Male	Female	P4GBA93	P4GBA13*
1/2"	65 (2.56)	-	31 (1.22)	78 (2.75)								Female	Female	P4GAA94	P4GAA14*
1/2"	80 (3.15)	65 (2.56)	31 (1.22)	85 (3.00)								Male	Female	P4GBA94	P4GBA14*
3/4"	76 (2.99)	-	30/36* (1.18/1.42*)	107 (3.77)								Female	Female	P4GAA96	P4GAA16*
1"	100 (3.94)	-	41/50* (1.61/1.97*)	300 (10.58)	(35 bar) 500 PSIG	-20°C to 120°C (-4°F to 248°F)	Housing: Aluminum Piston: Aluminum	Female	Female	P4GAA98	P4GAA18*				
2"	130 (5.12)	-	70/80* (2.76/3.15*)	775 (27.34)								Female	Female	P4GAA9C	P4GAA1C*

\* Note: BSP Threads Available Upon Request.

**How to Select the Optimal Size of an AirGuard**

Information based on an inlet pressure of 7 bar (100 PSIG)

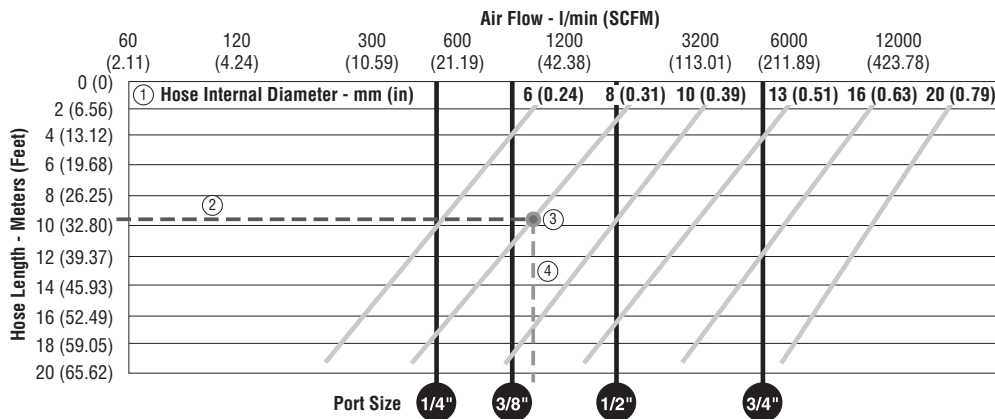

- Determine the internal diameter of the hose, tube or pipe being used ① (see specification Hose-internal Diameter, diagonal line).
- Determine the length of the hose, tube or pipe ② (Hose length in meters).
- Define the intersection of point a and b, and mark a vertical line downwards. ③ - ④ In the example chart (dot ③) and the dashed line ④).
- The next vertical black line, left of the intersection line ④ tells the correct AirGuard size (in inches).
- Important: Every flow value to the right of the respective vertical line (black) would activate the AirGuard in case of a bursting hose, pipe or tube. All AirGuard sizes right of the intersection line ④ are too big and will not close up.
- Example:** Which air fuse should be used for a hose, pipe or tube bearing 8 mm inner diameter and 10 meters of length - follow the 10 meter line (②) to the intersection point (dot ③). Now the next left black line marks the correct size.
- Result:** The correct size in our example is the AirGuard 3/8"



The WDV3 Electrical Drain is designed to remove condensate from compressors, compressed air dryers and receivers up to any size, type or manufacturer.

The WDV3 offers true installation simplicity and it is recognized as the most reliable and best performing condensate drain worldwide. The large orifice in the direct acting valve, combined with its sophisticated timer module ensure many years of trouble-free draining of condensate.

**Benefits**

- Does Not Air-Lock During Operation
- Compressed Air Systems Up to Any Size
- Also Available In Stainless Steel
- The Direct Acting Valve Is Serviceable
- Suitable for All Types of Compressors
- TEST (Micro-Switch) Feature
- High Time Cycle Accuracy
- Large (4.5mm) Valve Orifice

**Ordering Information**

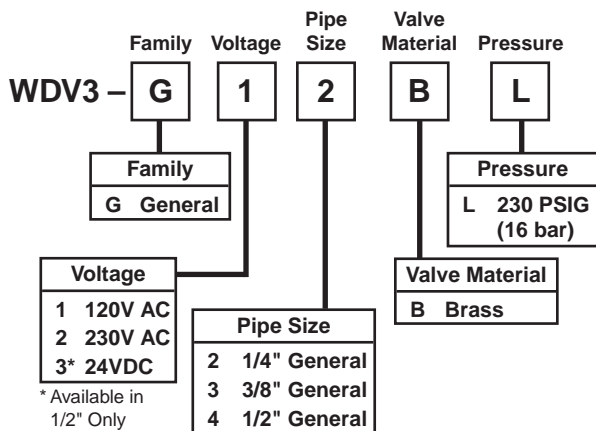

**Specifications**

- Operating Pressure**..... 230 PSIG (15,9 bar)
- Ambient Operating Range Temperature:**  
34° to 130°F (1.1° to 54°C)
- Coil Insulation**  
Class H ..... 340°F (171.1°C)
- Voltages**  
AC ..... 115, 230/50-60
- Timer:**  
Open Time ..... .5 to 10 sec., Adjustable  
Cycle Time..... .5 sec. to 45 min., Adjustable
- Maximum Current Rating** ..... 4mA Max.
- Port Size**..... 1/4, 3/8, 1/2 NPT
- Weight** ..... 1.8 lb. (0.8 kg)

**Materials of Construction**

- Valve Body** ..... Brass / Stainless Steel
- Enclosure (NEMA 4)**..... ABS Plastic
- Internal Parts** ..... Brass / Stainless Steel
- Sealing Material**..... FPM (Fluorocarbon)

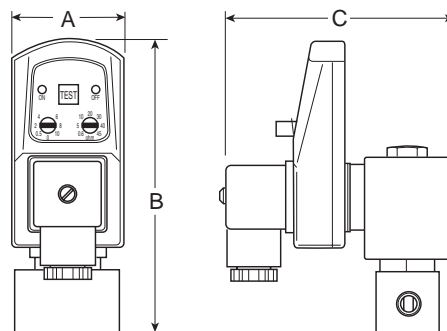

**Model Selection and Dimensions**

Model Number	A	B	C
WDV3-G**BL	1.73 (44)	4.53 (115)	3.46 (88)





Zero air loss condensate drains are designed for economical removal of unwanted water, oil emulsions, and other liquids. These drains will only open when liquid is present and will not allow any compressed air to escape from the system.

**Operating Information**

Maximum pressure	232 PSIG (16 bar)
Ambient operating temperature	35°F to 140°F (1.6°C to 60°C)
Voltages	NPT 115/50-60Hz, standard
Optional:	BSPP ports 230/50-60Hz & 24VDC

**Zero Air Loss Condensate Drains**

Port size (NPT)	Compressor Aftercooler (SCFM)*	Capacity Refrigeration Dryer (SCFM)**	Filter (SCFM)	Drain Capacity per Day (gal/liter)	Model Number	Service Kit
1 @ 3/8 (in), 1 @ 3/8 (out)	—	—	424	6 (22.7)	<b>ED3002N115-K</b>	<b>SKED3000N115</b>
1 @ 1/2 (in), 1 @ 3/8 (out)	141	282	1,413	13 (49.2)	<b>ED3004N115-K</b>	<b>SKED3000N115</b>
2 @ 1/2 (in), 1 @ 3/8 (out)	247	494	2,472	23 (87.1)	<b>ED3007N115-K</b>	<b>SKED3000N115</b>
2 @ 1/2 (in), 1 @ 3/8 (out)	1,059	2,119	10,594	100 (378.5)	<b>ED3030N115-K</b>	<b>SKED3000N115</b>
2 @ 1/2 (in), 1 @ 3/8 (out)	3,532	7,063	35,315	330 (1,249.2)	<b>ED3100N115-K</b>	<b>SKED3000N115</b>

\* Based on 100 PSI working pressure, air compressor inlet at 77°F (25°C) at 60% RH, air discharge temperature of 95°F (35°C) following the aftercooler, pressure dewpoint of 37°F (2.8°C) after the refrigerated dryer.

\*\* Condensate from aftercooler or refrigerated dryer to be drained upstream – only for residual oil content or small quantities of condensate.

Note: A 6 ft. line cord will be included with each drain.

**Where are condensate drains used?**

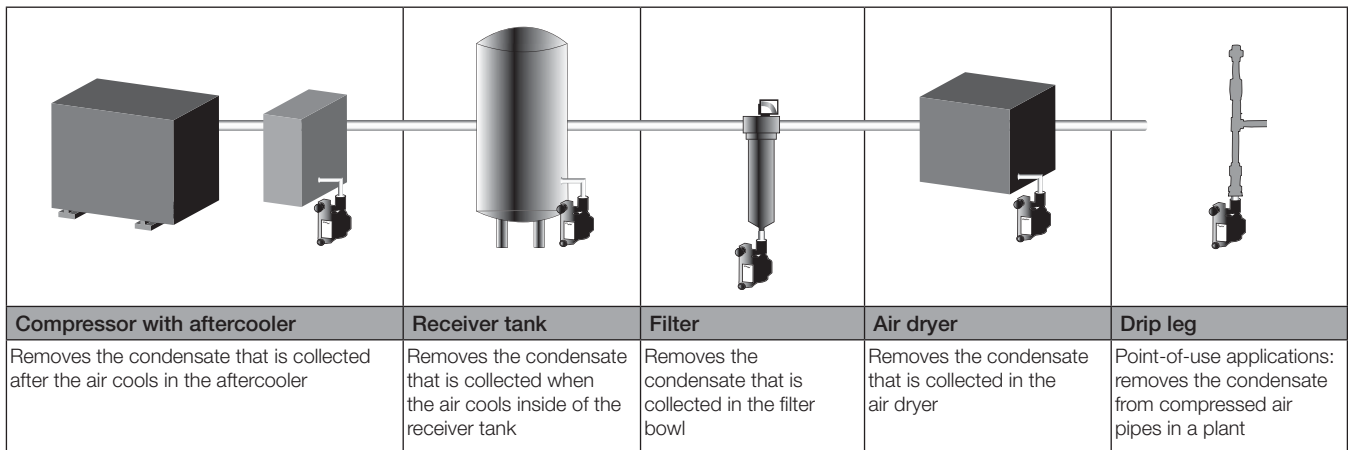

**Dimensions**

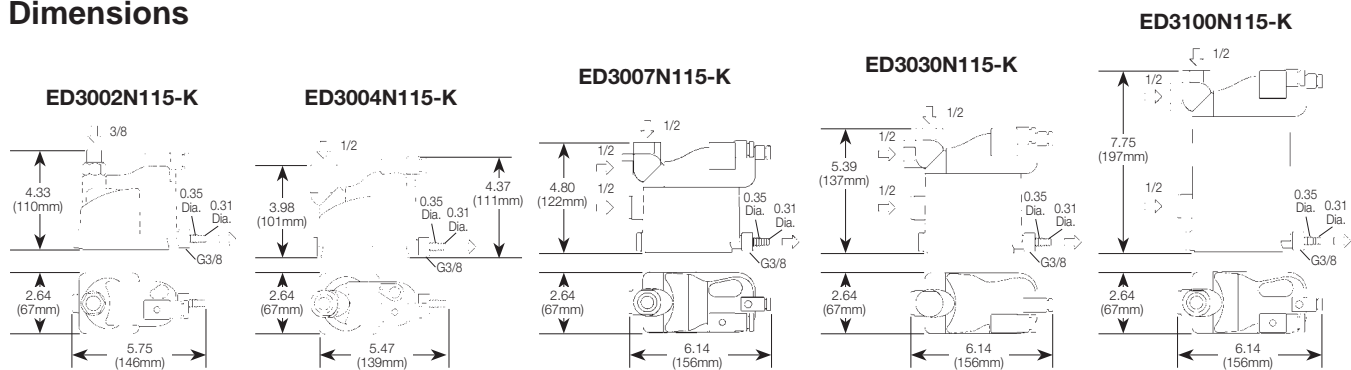

**O.S.H.A. Certification** — All safety blow guns conform to the requirements of Compressed Air Standards as currently described in the U.S. Bureau of Labor Standards, paragraph 1910.242, when pressurized at the inlet to a maximum of 100 PSIG. Conform to current O.S.H.A. Directive No. 100-1.

**Brass Nozzle Blow Guns**

Contoured lever or button control both provide a natural, comfortable grip even when used with gloves. Finger guard and hang-up hook for finger protection and quick safe storage. Die cast zinc body, painted finish.

**Lever Operated**

Part Number	Inlet Port	SCFM Rating*
00475 0010	1/4"	20

**Button Operated**

Part Number	Inlet Port	SCFM Rating*
00470 0010	1/4"	20

\*Based on 100 PSIG inlet pressure.

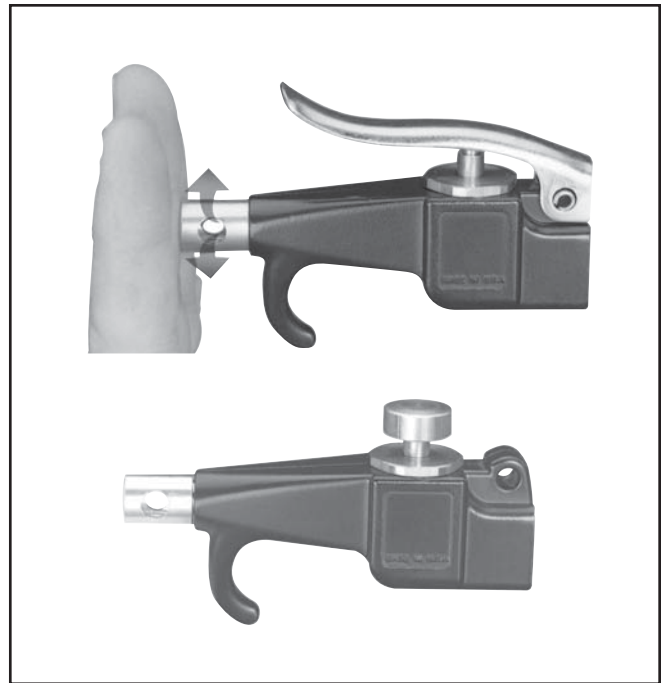

**Vortec FLO-GAIN Blow Guns**

A quiet Vortec FLO-GAIN nozzle is combined with a high performance blow gun. Compressed air attains sonic velocity through an adjustable slot and attaches to the exterior surface of the cone shaped nozzle. Settings are shown on a micrometer dial. Sound level of 80 dBA with 80 PSIG inlet. Finger guard and hang-up hook offers desirable finger protection and quick secure storage. Die cast zinc body, painted finish.

**Lever Operated**

Part Number	Inlet Port	SCFM Rating*
00475 0900	1/4"	70+

**Button Operated**

Part Number	Inlet Port	SCFM Rating*
00470 0900	1/4"	70+

\*Based on 100 PSIG inlet pressure.

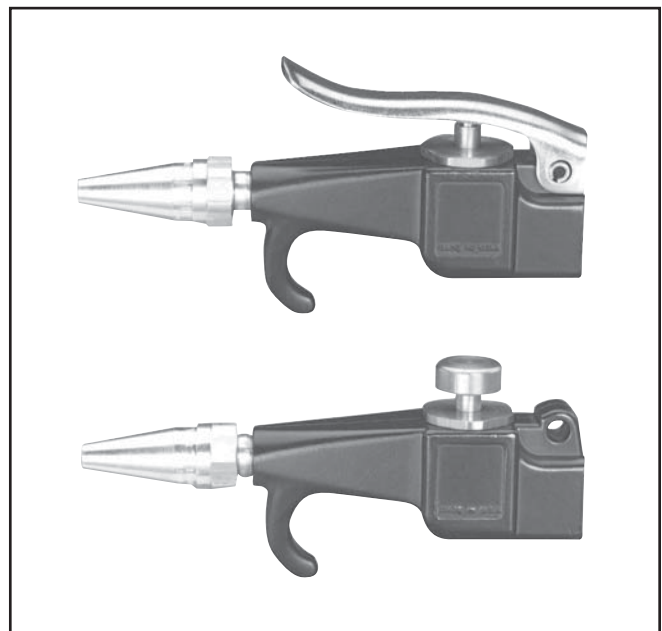

J

## Self-Regulating Blow Gun

Designed with integral self-regulating pressure reducing valve for automatic shut-off when nozzle is blocked. Prevents air pressure buildup over 30 PSIG in compliance with U.S. Dept. of Labor standards.

Air shield aids in protecting the operator against blow back of flying chips of dirt. Designed to operate at less than 90 dBA to comply with government regulations. Die cast zinc body, painted finish.

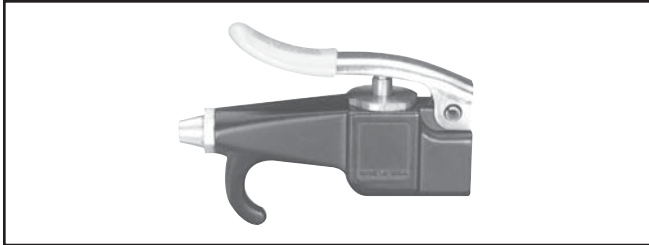

### Lever Operated

Part Number	Inlet Port	SCFM Rating*
00475 2900	1/4"	10

### Performance Data

Inlet Pressure	Blocked Pressure	Sound Level
70 PSIG	17.0 PSIG	79 dBA
100 PSIG	21.0 PSIG	83 dBA
175 PSIG	28.0 PSIG	87 dBA

\*Based on 100 PSIG inlet pressure.

## Pistol Grip Blow Gun

Pistol grip is easy to aim for quick and efficient cleaning. Ideal for all shop housekeeping purposes. Lightweight and easy to handle. Easy trigger action features instant spring adjustment for controlled air. Get the amount of air where you want it with no restrictions, no cut-offs! Makes for a convenient connection for overhead or under bench floor air use.

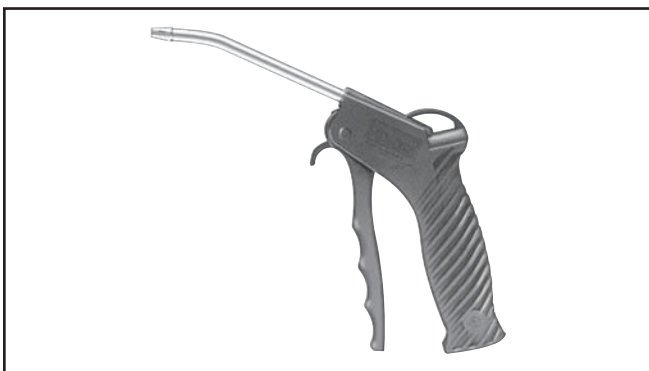

Part Number	Inlet Port	Rated Pressure	Temperature Range	OSHA Rated
BG441-NBL	1/4"	175 PSI	120° F	No

## Brass Nozzle

### Model No. 00470 7020

General purpose nozzles are supplied as standard on 00470 0010, 00475 0010 and 07184 1000 blow guns. Conform to the requirements of the Williams Steiger Occupational Safety and Health Act of 1970, paragraph 1910.242 when fitted with blow guns pressurized at the inlet to a maximum of 100 PSIG. Conform to O.S.H.A. Directive 100-1.

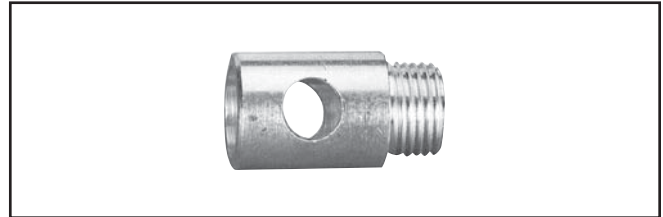

## FLO-GAIN Nozzle

### Model No. W1110 0900

This FLO-GAIN nozzle is the most widely used of the transvector products for industrial blow off. Compressed air attains sonic velocity through an adjustable slot and attaches to the cone shaped exterior surface of the nozzle. Induction and entrainment take place outside the nozzle. Factory slot setting is .008 inch, but is adjustable from closed to .012 inch. A micrometer dial allows adjustment without the use of shims or gauges.

Must be used with filtered air.

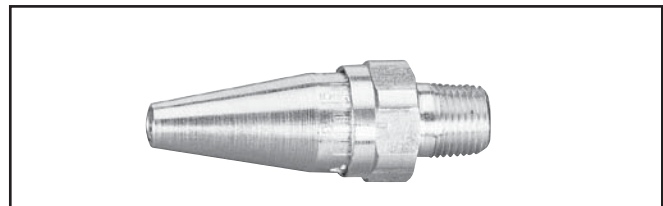

## 470 and 475 Series Blow Guns

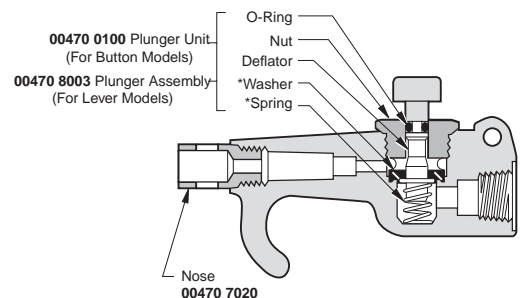

\* Contained in Service Kit No. 00470 0090

# Safety Guide For Selecting And Using Pneumatic Division Products And Related Accessories

## WARNING:

**FAILURE OR IMPROPER SELECTION OR IMPROPER USE OF PNEUMATIC DIVISION PRODUCTS, ASSEMBLIES OR RELATED ITEMS (“PRODUCTS”) CAN CAUSE DEATH, PERSONAL INJURY, AND PROPERTY DAMAGE. POSSIBLE CONSEQUENCES OF FAILURE OR IMPROPER SELECTION OR IMPROPER USE OF THESE PRODUCTS INCLUDE BUT ARE NOT LIMITED TO:**

- Unintended or mistimed cycling or motion of machine members or failure to cycle
- Work pieces or component parts being thrown off at high speeds.
- Failure of a device to function properly for example, failure to clamp or unclamp an associated item or device.
- Explosion
- Suddenly moving or falling objects.
- Release of toxic or otherwise injurious liquids or gasses.

Before selecting or using any of these Products, it is important that you read and follow the instructions below.

## 1. GENERAL INSTRUCTIONS

- 1.1. Scope:** This safety guide is designed to cover general guidelines on the installation, use, and maintenance of Pneumatic Division Valves, FRLs (Filters pressure Regulators and Lubricators), Vacuum products and related accessory components.
- 1.2. Fail-Safe:** Valves, FRLs, Vacuum products and their related components can and do fail without warning for many reasons. Design all systems and equipment in a fail-safe mode, so that failure of associated valves, FRLs or Vacuum products will not endanger persons or property.
- 1.3 Relevant International Standards:** For a good guide to the application of a broad spectrum of pneumatic fluid power devices see: ISO 4414:1998, Pneumatic Fluid Power – General Rules Relating to Systems. See [www.iso.org](http://www.iso.org) for ordering information.
- 1.4. Distribution:** Provide a copy of this safety guide to each person that is responsible for selection, installation, or use of Valves, FRLs or Vacuum products. Do not select, or use Watts valves, FRLs or vacuum products without thoroughly reading and understanding this safety guide as well as the specific Watts publications for the products considered or selected.
- 1.5. User Responsibility:** Due to the wide variety of operating conditions and applications for valves, FRLs, and vacuum products Watts and its distributors do not represent or warrant that any particular valve, FRL or vacuum product is suitable for any specific end use system. This safety guide does not analyze all technical parameters that must be considered in selecting a product. The user, through its own analysis and testing, is solely responsible for:
  - Making the final selection of the appropriate valve, FRL, Vacuum component, or accessory.
  - Assuring that all user's performance, endurance, maintenance, safety, and warning requirements are met and that the application presents no health or safety hazards.
  - Complying with all existing warning labels and / or providing all appropriate health and safety warnings on the equipment on which the valves, FRLs or Vacuum products are used; and,
  - Assuring compliance with all applicable government and industry standards.
- 1.6. Safety Devices:** Safety devices should not be removed, or defeated.
- 1.7. Warning Labels:** Warning labels should not be removed, painted over or otherwise obscured.
- 1.8. Additional Questions:** Call the appropriate Watts technical service department if you have any questions or require any additional information. See the Watts publication for the product being considered or used, or call 269-629-5000, or go to [www.wattsfluidair.com](http://www.wattsfluidair.com), for telephone numbers of the appropriate technical service department.

## 2. PRODUCT SELECTION INSTRUCTIONS

- 2.1. Flow Rate:** The flow rate requirements of a system are frequently the primary consideration when designing any pneumatic system. System components need to be able to provide adequate flow and pressure for the desired application.
- 2.2. Pressure Rating:** Never exceed the rated pressure of a product. Consult product labeling, Pneumatic Division catalogs or the instruction sheets supplied for maximum pressure ratings.
- 2.3. Temperature Rating:** Never exceed the temperature rating of a product. Excessive heat can shorten the life expectancy of a product and result in complete product failure.
- 2.4. Environment:** Many environmental conditions can affect the integrity and suitability of a product for a given application. Pneumatic Division products are designed for use in general purpose industrial applications. If these products are to be used in unusual circumstances such as direct sunlight and/or corrosive or caustic environments, such use can shorten the useful life and lead to premature failure of a product.
- 2.5. Lubrication and Compressor Carryover:** Some modern synthetic oils can and will attack nitrile seals. If there is any possibility of synthetic oils or greases migrating into the pneumatic components check for compatibility with the seal materials used. Consult the factory or product literature for materials of construction.
- 2.6. Polycarbonate Bowls and Sight Glasses:** To avoid potential polycarbonate bowl failures:
  - Do not locate polycarbonate bowls or sight glasses in areas where they could be subject to direct sunlight, impact blow, or temperatures outside of the rated range.
  - Do not expose or clean polycarbonate bowls with detergents, chlorinated hydro-carbons, ketones, esters or certain alcohols.
  - Do not use polycarbonate bowls or sight glasses in air systems where compressors are lubricated with fire resistant fluids such as phosphate ester and di-ester lubricants.

## Safety Guide

**2.7. Chemical Compatibility:** For more information on plastic component chemical compatibility see Pneumatic Division technical bulletins Tec-3, Tec-4, and Tec-5

**2.8. Product Rupture:** Product rupture can cause death, serious personal injury, and property damage.

- Do not connect pressure regulators or other Pneumatic Division products to bottled gas cylinders.
- Do not exceed the maximum primary pressure rating of any pressure regulator or any system component.
- Consult product labeling or product literature for pressure rating limitations.

### 3. PRODUCT ASSEMBLY AND INSTALLATION INSTRUCTIONS

**3.1. Component Inspection:** Prior to assembly or installation a careful examination of the valves, FRLs or vacuum products must be performed. All components must be checked for correct style, size, and catalog number. DO NOT use any component that displays any signs of nonconformance.

**3.2. Installation Instructions:** Watts published Installation Instructions must be followed for installation of Watts valves, FRLs and vacuum components. These instructions are provided with every Watts valve or FRL sold, or by calling 269-629-5000, or at [www.wattsfluidair.com](http://www.wattsfluidair.com).

**3.3. Air Supply:** The air supply or control medium supplied to Valves, FRLs and Vacuum components must be moisture-free if ambient temperature can drop below freezing

### 4. VALVE AND FRL MAINTENANCE AND REPLACEMENT INSTRUCTIONS

**4.1. Maintenance:** Even with proper selection and installation, valve, FRL and vacuum products service life may be significantly reduced without a continuing maintenance program. The severity of the application, risk potential from a component failure, and experience with any known failures in the application or in similar applications should determine the frequency of inspections and the servicing or replacement of Pneumatic Division products so that products are replaced before any failure occurs. A maintenance program must be established and followed by the user and, at minimum, must include instructions 4.2 through 4.10.

**4.2. Installation and Service Instructions:** Before attempting to service or replace any worn or damaged parts consult the appropriate Service Bulletin for the valve or FRL in question for the appropriate practices to service the unit in question. These Service and Installation Instructions are provided with every Watts valve and FRL sold, or are available by calling 269-629-5000, or by accessing the Watts web site at [www.wattsfluidair.com](http://www.wattsfluidair.com).

**4.3. Lockout / Tagout Procedures:** Be sure to follow all required lockout and tagout procedures when servicing equipment. For more information see: OSHA Standard – 29 CFR, Part 1910.147, Appendix A, The Control of Hazardous Energy – (Lockout / Tagout)

**4.4. Visual Inspection:** Any of the following conditions requires immediate system shut down and replacement of worn or damaged components:

- Air leakage: Look and listen to see if there are any signs of visual damage to any of the components in the system. Leakage is an indication of worn or damaged components.
- Damaged or degraded components: Look to see if there are any visible signs of wear or component degradation.
- Kinked, crushed, or damaged hoses. Kinked hoses can result in restricted air flow and lead to unpredictable system behavior.
- Any observed improper system or component function: Immediately shut down the system and correct malfunction.
- Excessive dirt build-up: Dirt and clutter can mask potentially hazardous situations.

**Caution: Leak detection solutions should be rinsed off after use.**

**4.5. Routine Maintenance Issues:**

- Remove excessive dirt, grime and clutter from work areas.
- Make sure all required guards and shields are in place.

**4.6. Functional Test:** Before initiating automatic operation, operate the system manually to make sure all required functions operate properly and safely.

**4.7. Service or Replacement Intervals:** It is the user's responsibility to establish appropriate service intervals. Valves, FRLs and vacuum products contain components that age, harden, wear, and otherwise deteriorate over time. Environmental conditions can significantly accelerate this process. Valves, FRLs and vacuum components need to be serviced or replaced on routine intervals. Service intervals need to be established based on:

- Previous performance experiences.
- Government and / or industrial standards.
- When failures could result in unacceptable down time, equipment damage or personal injury risk.

**4.8. Servicing or Replacing of any Worn or Damaged Parts:** To avoid unpredictable system behavior that can cause death, personal injury and property damage:

- Follow all government, state and local safety and servicing practices prior to service including but not limited to all OSHA Lockout Tagout procedures (OSHA Standard – 29 CFR, Part 1910.147, Appendix A, The Control of Hazardous Energy – Lockout / Tagout).
- Disconnect electrical supply (when necessary) before installation, servicing, or conversion.
- Disconnect air supply and depressurize all air lines connected to system and Pneumatic Division products before installation, service, or conversion.
- Installation, servicing, and / or conversion of these products must be performed by knowledgeable personnel who understand how pneumatic products are to be applied.
- After installation, servicing, or conversions air and electrical supplies (when necessary) should be connected and the product tested for proper function and leakage. If audible leakage is present, or if the product does not operate properly, do not put product or system into use.
- Warnings and specifications on the product should not be covered or painted over. If masking is not possible, contact your local representative for replacement labels.

**4.9. Putting Serviced System Back into Operation:** Follow the guidelines above and all relevant Installation and Maintenance Instructions supplied with the valve FRL or vacuum component to insure proper function of the system.

The items described in this document and other documents and descriptions provided by Parker Hannifin Corporation, its subsidiaries and its authorized distributors ("Seller") are hereby offered for sale at prices to be established by Seller. This offer and its acceptance by any customer ("Buyer") shall be governed by all of the following Terms and Conditions. Buyer's order for any item described in its document, when communicated to Seller verbally, or in writing, shall constitute acceptance of this offer. All goods or work described will be referred to as "Products".

**1. Terms and Conditions.** Seller's willingness to offer Products, or accept an order for Products, to or from Buyer is expressly conditioned on Buyer's assent to these Terms and Conditions and to the terms and conditions found on-line at [www.parker.com/saleterms/](http://www.parker.com/saleterms/). Seller objects to any contrary or additional term or condition of Buyer's order or any other document issued by Buyer.

**2. Price Adjustments; Payments.** Prices stated on the reverse side or preceding pages of this document are valid for 30 days. After 30 days, Seller may change prices to reflect any increase in its costs resulting from state, federal or local legislation, price increases from its suppliers, or any change in the rate, charge, or classification of any carrier. The prices stated on the reverse or preceding pages of this document do not include any sales, use, or other taxes unless so stated specifically. Unless otherwise specified by Seller, all prices are F.O.B. Seller's facility, and payment is due 30 days from the date of invoice. After 30 days, Buyer shall pay interest on any unpaid invoices at the rate of 1.5% per month or the maximum allowable rate under applicable law.

**3. Delivery Dates; Title and Risk; Shipment.** All delivery dates are approximate and Seller shall not be responsible for any damages resulting from any delay. Regardless of the manner of shipment, title to any products and risk of loss or damage shall pass to Buyer upon tender to the carrier at Seller's facility (i.e., when it's on the truck, it's yours). Unless otherwise stated, Seller may exercise its judgment in choosing the carrier and means of delivery. No deferral of shipment at Buyers' request beyond the respective dates indicated will be made except on terms that will indemnify, defend and hold Seller harmless against all loss and additional expense. Buyer shall be responsible for any additional shipping charges incurred by Seller due to Buyer's changes in shipping, product specifications or in accordance with Section 13, herein.

**4. Warranty.** Seller warrants that the Products sold hereunder shall be free from defects in material or workmanship for a period of twelve months from the date of delivery to Buyer or 2,000 hours of normal use, whichever occurs first. This warranty is made only to Buyer and does not extend to anyone to whom Products are sold after purchased from Seller. The prices charged for Seller's products are based upon the exclusive limited warranty stated above, and upon the following disclaimer: **DISCLAIMER OF WARRANTY: THIS WARRANTY COMPRISES THE SOLE AND ENTIRE WARRANTY PERTAINING TO PRODUCTS PROVIDED HEREUNDER. SELLER DISCLAIMS ALL OTHER WARRANTIES, EXPRESS AND IMPLIED, INCLUDING MERCHANTABILITY AND FITNESS FOR A PARTICULAR PURPOSE.**

**5. Claims; Commencement of Actions.** Buyer shall promptly inspect all Products upon delivery. No claims for shortages will be allowed unless reported to the Seller within 10 days of delivery. No other claims against Seller will be allowed unless asserted in writing within 60 days after delivery or, in the case of an alleged breach of warranty, within 30 days after the date within the warranty period on which the defect is or should have been discovered by Buyer. Any action based upon breach of this agreement or upon any other claim arising out of this sale (other than an action by Seller for any amount due to Seller from Buyer) must be commenced within thirteen months from the date of tender of delivery by Seller or, for a cause of action based upon an alleged breach of warranty, within thirteen months from the date within the warranty period on which the defect is or should have been discovered by Buyer.

**6. LIMITATION OF LIABILITY.** UPON NOTIFICATION, SELLER WILL, AT ITS OPTION, REPAIR OR REPLACE A DEFECTIVE PRODUCT, OR REFUND THE PURCHASE PRICE. IN NO EVENT SHALL SELLER BE LIABLE TO BUYER FOR ANY SPECIAL, INDIRECT, INCIDENTAL OR CONSEQUENTIAL DAMAGES ARISING OUT OF, OR AS THE RESULT OF, THE SALE, DELIVERY, NON-DELIVERY, SERVICING, USE OR LOSS OF USE OF THE PRODUCTS OR ANY PART THEREOF, OR FOR ANY CHARGES OR EXPENSES OF ANY NATURE INCURRED WITHOUT SELLER'S WRITTEN CONSENT, EVEN IF SELLER HAS BEEN NEGLIGENT, WHETHER IN CONTRACT, TORT OR OTHER LEGAL THEORY. IN NO EVENT SHALL SELLER'S LIABILITY UNDER ANY CLAIM MADE BY BUYER EXCEED THE PURCHASE PRICE OF THE PRODUCTS.

**7. Contingencies.** Seller shall not be liable for any default or delay in performance if caused by circumstances beyond the reasonable control of Seller.

**8. User Responsibility.** The user, through its own analysis and testing, is solely responsible for making the final selection of the system and Product and assuring that all performance, endurance, maintenance, safety and warning requirements of the application are met. The user must analyze all aspects of the application and follow applicable industry standards and Product information. If Seller provides Product or system options, the user is responsible for determining that such data and specifications are suitable and sufficient for all applications and reasonably foreseeable uses of the Products or systems.

**9. Loss to Buyer's Property.** Any designs, tools, patterns, materials, drawings, confidential information or equipment furnished by Buyer or any other items which become Buyer's property, may be considered obsolete and may be destroyed by Seller after two consecutive years have elapsed without Buyer placing an order for the items which are manufactured using such property. Seller shall not be responsible for any loss or damage to such property while it is in Seller's possession or control.

**10. Special Tooling.** A tooling charge may be imposed for any special tooling, including without limitation, dies, fixtures, molds and patterns, acquired to manufacture Products. Such special tooling shall be and remain Seller's property notwithstanding payment of any charges by Buyer. In no event will Buyer acquire any interest in apparatus belonging to Seller which is utilized in the manufacture of the Products, even if such apparatus has been specially converted or adapted for such manufacture and notwithstanding any charges paid by Buyer. Unless otherwise agreed, Seller shall have the right to alter, discard or otherwise dispose of any special tooling or other property in its sole discretion at any time.

**11. Buyer's Obligation; Rights of Seller.** To secure payment of all sums due or otherwise, Seller shall retain a security interest in the goods delivered and this agreement shall be deemed a Security Agreement under the Uniform Commercial Code. Buyer authorizes Seller as its attorney to execute and file on Buyer's behalf all documents Seller deems necessary to perfect its security interest. Seller shall have a security interest in, and lien upon, any property of Buyer in Seller's possession as security for the payment of any amounts owed to Seller by Buyer.

**12. Improper use and Indemnity.** Buyer shall indemnify, defend, and hold Seller harmless from any claim, liability, damages, lawsuits, and costs (including attorney fees), whether for personal injury, property damage, patent, trademark or copyright infringement or any other claim, brought by or incurred by Buyer, Buyer's employees, or any other person, arising out of: (a) improper selection, improper application or other misuse of Products purchased by Buyer from Seller; (b) any act or omission, negligent or otherwise, of Buyer; (c) Seller's use of patterns, plans, drawings, or specifications furnished by Buyer to manufacture Product; or (d) Buyer's failure to comply with these terms and conditions. Seller shall not indemnify Buyer under any circumstance except as otherwise provided.

**13. Cancellations and Changes.** Orders shall not be subject to cancellation or change by Buyer for any reason, except with Seller's written consent and upon terms that will indemnify, defend and hold Seller harmless against all direct, incidental and consequential loss or damage. Seller may change product features, specifications, designs and availability with notice to Buyer.

**14. Limitation on Assignment.** Buyer may not assign its rights or obligations under this agreement without the prior written consent of Seller.

**15. Entire Agreement.** This agreement contains the entire agreement between the Buyer and Seller and constitutes the final, complete and exclusive expression of the terms of the agreement. All prior or contemporaneous written or oral agreements or negotiations with respect to the subject matter are herein merged.

**16. Waiver and Severability.** Failure to enforce any provision of this agreement will not waive that provision nor will any such failure prejudice Seller's right to enforce that provision in the future. Invalidation of any provision of this agreement by legislation or other rule of law shall not invalidate any other provision herein. The remaining provisions of this agreement will remain in full force and effect.

**17. Termination.** This agreement may be terminated by Seller for any reason and at any time by giving Buyer thirty (30) days written notice of termination. In addition, Seller may by written notice immediately terminate this agreement for the following: (a) Buyer commits a breach of any provision of this agreement (b) the appointment of a trustee, receiver or custodian for all or any part of Buyer's property (b) the filing of a petition for relief in bankruptcy of the other Party on its own behalf, or by a third party (c) an assignment for the benefit of creditors, or (d) the dissolution or liquidation of the Buyer.

**18. Governing Law.** This agreement and the sale and delivery of all Products hereunder shall be deemed to have taken place in and shall be governed and construed in accordance with the laws of the State of Ohio, as applicable to contracts executed and wholly performed therein and without regard to conflicts of laws principles. Buyer irrevocably agrees and consents to the exclusive jurisdiction and venue of the courts of Cuyahoga County, Ohio with respect to any dispute, controversy or claim arising out of or relating to this agreement. Disputes between the parties shall not be settled by arbitration unless, after a dispute has arisen, both parties expressly agree in writing to arbitrate the dispute.

**19. Indemnity for Infringement of Intellectual Property Rights.** Seller shall have no liability for infringement of any patents, trademarks, copyrights, trade dress, trade secrets or similar rights except as provided in this Section. Seller will defend and indemnify Buyer against allegations of infringement of U.S. patents, U.S. trademarks, copyrights, trade dress and trade secrets ("Intellectual Property Rights"). Seller will defend at its expense and will pay the cost of any settlement or damages awarded in an action brought against Buyer based on an allegation that a Product sold pursuant to this Agreement infringes the Intellectual Property Rights of a third party. Seller's obligation to defend and indemnify Buyer is contingent on Buyer notifying Seller within ten (10) days after Buyer becomes aware of such allegations of infringement, and Seller having sole control over the defense of any allegations or actions including all negotiations for settlement or compromise. If a Product is subject to a claim that it infringes the Intellectual Property Rights of a third party, Seller may, at its sole expense and option, procure for Buyer the right to continue using the Product, replace or modify the Product so as to make it noninfringing, or offer to accept return of the Product and return the purchase price less a reasonable allowance for depreciation. Notwithstanding the foregoing, Seller shall have no liability for claims of infringement based on information provided by Buyer, or directed to Products delivered hereunder for which the designs are specified in whole or part by Buyer, or infringements resulting from the modification, combination or use in a system of any Product sold hereunder. The foregoing provisions of this Section shall constitute Seller's sole and exclusive liability and Buyer's sole and exclusive remedy for infringement of Intellectual Property Rights.

**20. Taxes.** Unless otherwise indicated, all prices and charges are exclusive of excise, sales, use, property, occupational or like taxes which may be imposed by any taxing authority upon the manufacture, sale or delivery of Products.

**21. Equal Opportunity Clause.** For the performance of government contracts and where dollar value of the Products exceed \$10,000, the equal employment opportunity clauses in Executive Order 11246, VEVRAA, and 41 C.F.R. §§ 60-1.4(a), 60-741.5(a), and 60-250.4, are hereby incorporated.