

Warning, Offer of Sale

 WARNING

FAILURE OR IMPROPER SELECTION OR IMPROPER USE OF THE PRODUCTS AND/OR SYSTEMS DESCRIBED HEREIN OR RELATED ITEMS CAN CAUSE DEATH, PERSONAL INJURY AND PROPERTY DAMAGE.

This document and other information from Parker Hannifin Corporation, its subsidiaries and authorized distributors provide product and/or system options for further investigation by users having technical expertise. It is important that you analyze all aspects of your application including consequences of any failure, and review the information concerning the product or system in the current product catalog. Due to the variety of operating conditions and applications for these products or systems, the user, through its own analysis and testing, is solely responsible for making the final selection of the products and systems and assuring that all performance, safety and warning requirements of the application are met.

The products described herein, including without limitation, product features, specifications, designs, availability and pricing, are subject to change by Parker Hannifin Corporation and its subsidiaries at any time without notice.

Offer of Sale

The items described in this document are hereby offered for sale by Parker Hannifin Corporation, its subsidiaries or its authorized distributors. This offer and its acceptance are governed by the provisions stated on the separate page of this document entitled "Offer of Sale".

© Copyright 2011, 2008, 2001 Parker Hannifin Corporation. All Rights Reserved

Table of Contents

QUBE Modular FRL System	A QUBE Modular FRL System
Air Preparation Units	B Air Preparation Units
Precision and Proportional Regulators	C Precision & Proportional Regulators
Miniature FRL's	D Miniature FRLs
Stainless Steel FRL's	E Stainless Steel FRLs
Control Panel Products	F Control Panels
LV / EZ Lockout Valves	G LV / EZ Lockout Valves
Integrated Fittings	H Integrated Fittings
Accessories	J Accessories
Ball Valves / Plug Valves	K Ball Valves / Plug Valves
Quick Couplings	L Quick Couplings
Hose & Fittings	M Hose & Fittings
Tubing & Fittings	N Tubing & Fittings
Safety Guide, Offer of Sale	P Safety Guide, Offer of Sale

Section L



Industrial Interchange Nipples..... L2-L3
Sleevmatic Couplers..... L4-L6
Saflomatic Couplers L7-L8
Economatic Quick Connect Couplings L9-L10

Description

Industrial interchange nipples conform to MIL-C4109 and are for use with either Sleeveomatic or Saflomatic couplers. The industrial interchange nipples are completely interchangeable with similar nipples manufactured by other quick coupling manufacturers conforming to A-A-59439 (formerly known as MIL-C-4109F), ANSI/(NFPA) T3.20.14-1990, or ISO6150-B requirements.

Hardened wear points and solid barstock construction provide long service life. Precision machined surfaces and hardened load-bearing areas resist the effects of mechanical shock in the most rugged applications.

Female Pipe Thread

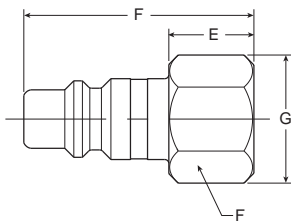

Male Pipe Thread

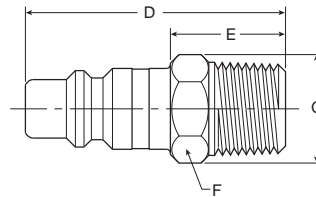

Body Size (Inches)	Part No. Steel	Thread Size	Overall Length D	Exposed Length* E	Hex Size F	Largest Diameter G
1/4	H1C	1/8-27	1.48	0.71	0.50	0.58
1/4	H3C	1/4-18	1.56	0.80	0.62	0.72
1/4	H3C-E	3/8-18	1.60	0.83	0.81	0.94
3/8	H1E	1/4-18	1.60	0.69	0.62	0.72
3/8	H3E	3/8-18	1.69	0.74	0.81	0.94
3/8	H3E-F	1/2-14	1.84	0.90	1.00	1.16
1/2	H1F	3/8-18	2.03	0.79	0.81	0.94
1/2	H3F	1/2-14	2.20	0.96	1.00	1.16
1/2	H3F-G	3/4-14	2.30	1.05	1.25	1.44
3/4	H3G-F	1/2-14	2.22	1.06	1.00	1.16
3/4	H3G	3/4-14	2.18	1.02	1.25	1.44
3/4	H3G-J	1-11½	2.41	1.25	1.63	1.80

* This dimension represents portion of nipple that is exposed when nipple is inserted in the coupler.

Body Size (Inches)	Part No. Steel	Thread Size	Overall Length D	Exposed Length* E	Hex Size F	Largest Diameter G
1/4	H0C	1/8-27	1.68	0.92	0.50	0.58
1/4	H2C	1/4-18	1.66	0.89	0.56	0.65
1/4	H2C-E	3/8-18	1.90	1.14	0.69	0.80
3/8	H00E	1/8-27	1.68	0.73	0.62	0.72
3/8	H0E	1/4-18	1.90	0.95	0.62	0.72
3/8	H2E	3/8-18	1.90	0.95	0.69	0.80
3/8	H2E-F	1/2-14	2.03	1.09	0.88	1.02
1/2	H0F	3/8-18	2.20	0.96	0.69	0.79
1/2	H2F	1/2-14	2.35	1.09	0.88	1.01
1/2	H2F-G	3/4-14	2.40	1.16	1.06	1.22
3/4	H2G-F	1/2-14	2.32	1.16	1.00	1.16
3/4	H2G	3/4-14	2.28	1.12	1.06	1.22
3/4	H2G-J	1-11½	2.56	1.40	1.31	1.52

* This dimension represents portion of nipple that is exposed when nipple is inserted in the coupler.

Standard Hose Barb

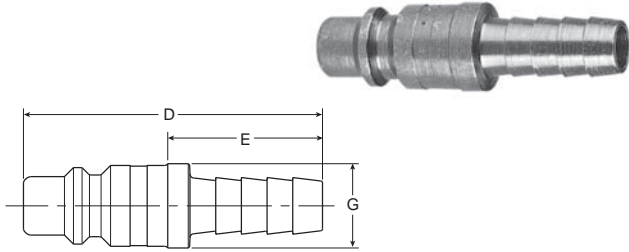

Body Size (Inches)	Part No. Steel	Hose I.D.	Overall Length D	Exposed Length* E	Largest Diameter G
1/4	H8C	1/4	1.72	0.95	0.46
1/4	H8C-D	5/16	1.96	1.20	0.50
1/4	H9C	3/8	1.96	1.20	0.50
3/8	H5E	3/8	1.85	0.90	0.59
3/8	H6E	1/2	2.09	1.14	0.68
1/2	H4F	3/8	2.36	1.12	0.66
1/2	H5F	1/2	2.36	1.12	0.66
1/2	H5F-G	3/4	2.95	1.71	0.87
3/4	H5G-F	1/2	2.47	1.31	0.93
3/4	H5G	3/4	3.00	1.84	0.93
3/4	H5G-J	1	3.24	2.08	1.24

* This dimension represents portion of nipple that is exposed when nipple is inserted in coupler.

Push-Lok Hose Barb**

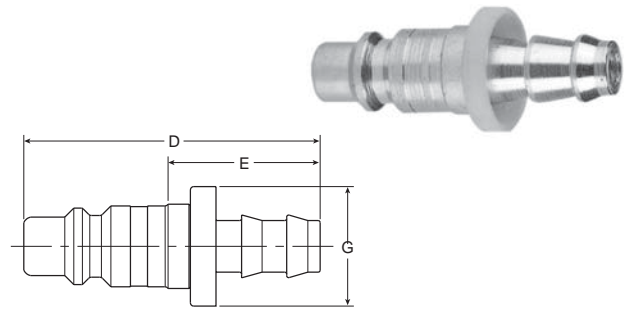

Body Size (Inches)	Part No. Steel	Hose I.D.	Overall Length D	Exposed Length* E	Largest Diameter G
1/4	H8CP	1/4	1.93	1.16	0.69
1/4	H9CP	3/8	2.08	1.31	0.86
3/8	H4EP	1/4	2.02	1.08	0.69
3/8	H5EP	3/8	2.17	1.23	0.88
3/8	H6EP	1/2	2.31	1.37	0.97
1/2	H4FP	3/8	2.52	1.27	0.88
1/2	H5FP	1/2	2.66	1.42	0.97
1/2	H6FP	1/2	2.95	1.71	1.14

* This dimension represents portion of nipple that is exposed when nipple is inserted in coupler.

** Push-Lok hose barbs are designed for use with a push-lok hose and do not require clamps.



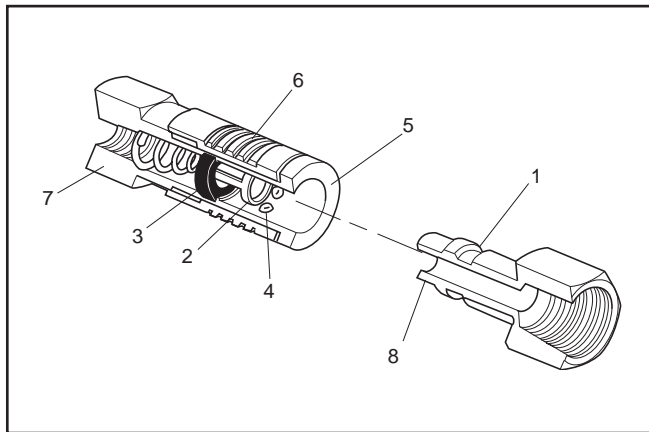
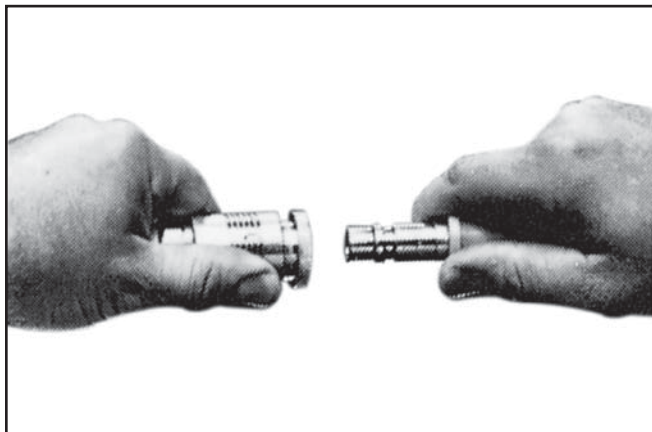

Operation

Sleeve type couplings are widely used to connect air and low-pressure fluid hose lines.

Their compact and economical design uses a ball locking mechanism consisting of captive steel balls that engage the locking groove on the mating nipple. As pictured, the sliding spring loaded sleeve on the coupler must be manually retracted in order to connect or disconnect the nipple. It is easy to do, but two hands are normally required.

Common applications include compressed air, water, grease, paint, limited vacuum and limited gases.

Features

1. Hardened wear points and solid barstock construction provide long life for these quality couplings. Precision machined surfaces resist the effects of mechanical shocks, even in rugged use.
2. Tubular valve with large flow passages delivers high air flows with minimal pressure drop for efficient performance.
3. Molded seals with high quality valve seats form a bubble tight seal for reliable sealing within rated working pressures. The tubular valve minimizes wear on the seal and prolongs seal life.
4. Ball locking mechanism with large numbers of steel or stainless steel locking balls improves resistance to wear, insures positive connections and provides accurate alignment. The ball locking also allows swiveling action that reduces hose torque.
5. Sleeve guard resists accidental disconnection by allowing the coupling to ride over obstructions without the sleeve being accidentally retracted. It also contributes to greater strength.
6. Knurling and grooves on sleeve provide gripping surfaces for ease of operation.
7. Wide range of sizes, materials and end terminations are available. Sleeve type quick couplings are offered with male pipe, female pipe, push-lok hose barb and standard hose barb ends. Materials offered are Nitrile, Ethylene, Propylene and Fluorocarbon for seals and brass or steel for metals.
8. Interchangeability. Sleeve type couplings are used with industrial interchange nipples conforming to MIL-C4109.

Specifications

	Body Size		
	1/4	3/8	1/2
Rated Pressure (psi)	300	300	300
Temperature Range			
Nitrile	-40°F to 250°F		
Ethylene Propylene	-65°F to 400°F		
Fluorocarbon	-30°F to 400°F		
Locking Device	4 Balls	8 Balls	8 Balls
Vacuum Data (inches Hg)*			
Disconnected (coupler only)	Not recommended		
Connected	27.4	27.4	27.4

* Couplings for vacuum service should be 100% tested – an extra cost service. Consult factory.

Performance

Sleevmatic

1/4", 3/8", 1/2"

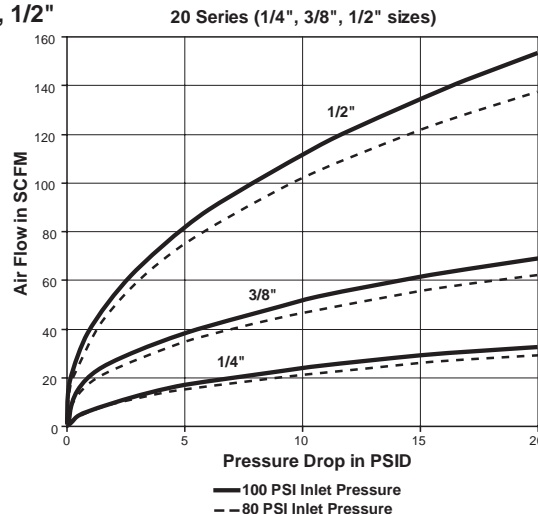

Female Pipe Thread

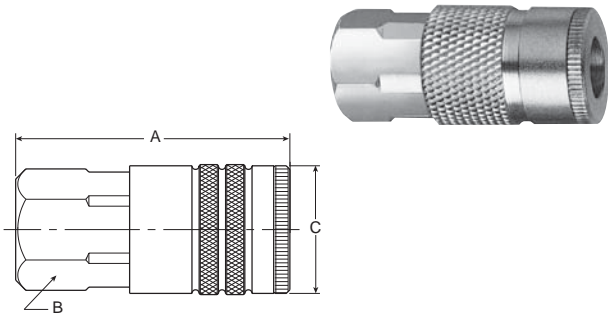

Body Size (Inches)	Part No.		Thread Size	Overall Length A	Hex Size B	Largest Diameter C
	Brass	Steel				
1/4	B23A	—	1/8-27	1.83	0.75	0.90
1/4	B23	—	1/4-18	1.83	0.75	0.90
1/4	B23E	—	3/8-18	1.95	0.81	0.94
3/8	—	25C	1/4-18	2.22	0.88	1.06
3/8	—	25	3/8-18	2.28	0.88	1.06
3/8	—	25F	1/2-14	2.55	1.00	1.16
1/2	—	17E	3/8-18	2.74	1.00	1.19
1/2	—	17	1/2-14	2.96	1.00	1.19
1/2	—	17G	3/4-14	3.19	1.25	1.44

Male Pipe Thread

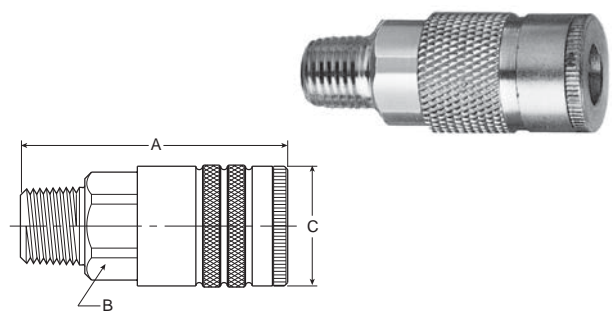

Body Size (Inches)	Part No.		Thread Size	Overall Length A	Hex Size B	Largest Diameter C
	Brass	Steel				
1/4	B22A	—	1/8-27	1.89	0.75	0.90
1/4	B22	—	1/4-18	2.05	0.75	0.90
1/4	B22E	—	3/8-18	2.08	0.75	0.90
3/8	—	24C	1/4-18	2.36	0.88	1.06
3/8	—	24	3/8-18	2.39	0.88	1.06
3/8	—	24F	1/2-14	2.55	0.88	1.06
1/2	—	16E	3/8-18	2.93	1.00	1.19
1/2	—	16	1/2-14	3.08	1.00	1.19
1/2	—	16G	3/4-14	3.21	1.13	1.30

NOTE: To indicate Fluorocarbon seals, add the letter Y as a suffix to the catalog number of the coupler. To indicate Ethylene Propylene seals, add the letter W as a suffix to the catalog number of the coupler.
 Example: B23AY or B23AW



Standard Hose Barb

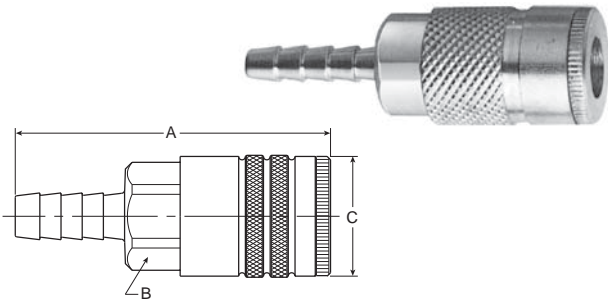

Body Size (Inches)	Part No.		Hose I.D.	Overall Length A	Hex Size B	Largest Diameter C
	Brass	Steel				
1/4	B20-3B	—	1/4	2.49	0.75	0.90
1/4	B20-4B	—	5/16	2.49	0.75	0.90
1/4	B20-5B	—	3/8	2.49	0.75	0.90
3/8	—	24-5B	3/8	2.86	0.88	1.06
3/8	—	24-6B	1/2	3.08	0.88	1.06
1/2	—	16-5B	3/8	3.37	1.00	1.19
1/2	—	16-6B	1/2	3.62	1.00	1.19
1/2	—	16-7B	3/4	3.96	1.00	1.19

Push-Lok Hose Barb*

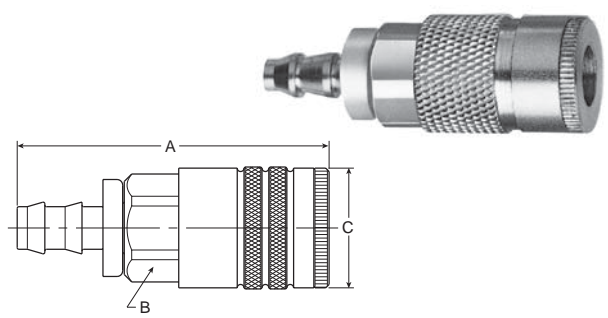

Body Size (Inches)	Part No.		Hose I.D.	Overall Length A	Hex Size B	Largest Diameter C
	Brass	Steel				
1/4	B20-3BP	—	1/4	2.32	0.75	0.90
1/4	B20-5BP	—	3/8	2.47	0.75	0.90
3/8	—	24-5BP	3/8	2.88	0.88	1.06
1/2	—	16-5BP	3/8	3.35	1.00	1.19
1/2	—	16-6BP	1/2	3.46	1.00	1.19

* Push-Lok hose barbs are designed for use with push-lok hose and do not require clamps.

NOTE: To indicate Fluorocarbon seals, add the letter Y as a suffix to the catalog number of the coupler. To indicate Ethylene Propylene seals, add the letter W as a suffix to the catalog number of the coupler.
 Example: B20-3BY or B20-3BW

Repair Kits

Body Size	Nitrile	Fluorocarbon	Ethylene Propylene
1/4	21K	21KY	21KW
3/8	14K	—	14KW
1/2	16K	16KY	16KW



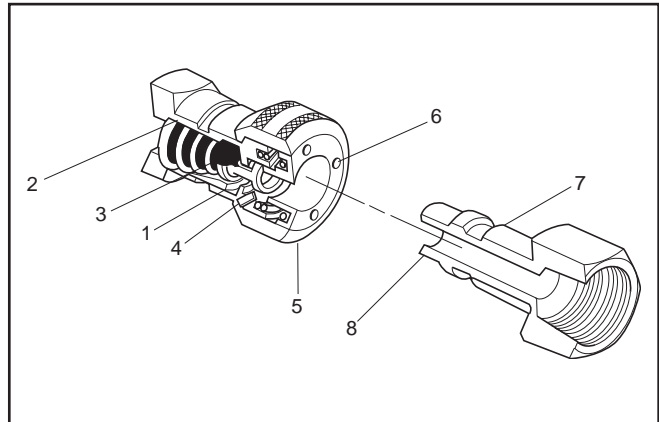
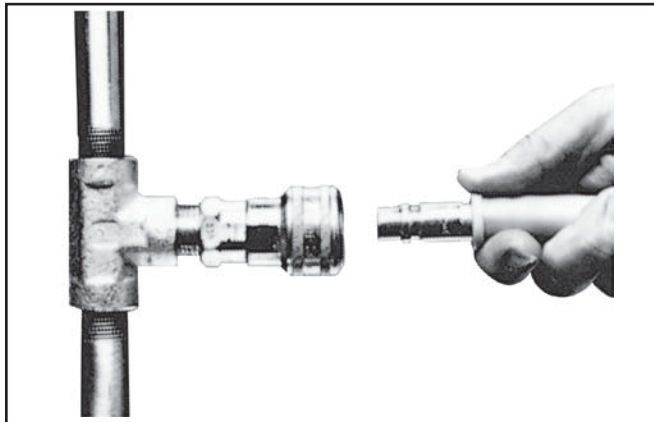

Operation

Push type couplings feature one-handed “automatic” connection by pushing the nipple into the coupler – provided the coupler half is firmly mounted.

The locking mechanism of Safromatic push type couplers consists of pawls or pins which act directly on the sleeve, thereby causing the sleeve to automatically retract when the mating nipple is inserted. The sleeve must be manually retracted in order to remove the nipple.

Safromatic couplings are push type “single shut off” couplings.

Common applications include compressed air, water, grease, paint, limited vacuum and limited gas.

Features

1. Safromatic tubular valves with their large flow windows deliver high air flow with minimum pressure drop – for efficient performance of air tools and other actuators. The tubular valve also provides 360 degree seal support to prevent cold flow and bore constriction, thereby extending seal life.

2. Tapered flow recesses in the valve body provide maximum flow capability.
3. Precision molded seals with high quality valve seats for a bubble tight seal that assures reliable sealing within rated working pressures. The Safromatic design with its 360° seal support gives maximum seal retention.
4. Locking pawls are of hardened stainless steel for a durable locking mechanism that provides good alignment and sideload resistance.
5. Push-to-connect design permits one-handed connection when the coupler half is rigidly mounted.
6. Back pressure vent holes allow easier connections especially with liquids.
7. Hardened wear points and solid barstock construction provide long life for these quality couplings. Precision machined surfaces resist the effects of mechanical shocks, even in rugged use.
8. Interchangeability. Safromatic couplers are used with industrial interchange nipples conforming to MIL-C4109.

Specifications

	Body Size			
	1/4	3/8	1/2	3/4
Rated Pressure (psi)	300	300	300	300
Temperature Range				
Nitrile	-40°F to 250°F			
Ethylene Propylene	-65°F to 400°F			
Fluorocarbon	-30°F to 400°F			
Locking Device	3	4	5	6
	pawls	pawls	pawls	pawls
Vacuum Data (inches Hg)*				
Disconnected (coupler only)	Not recommended			
Connected	27.4	27.4	27.4	27.4

* Couplings for vacuum service should be 100% tested – an extra cost service. Consult factory.

Performance

**Safromatic
1/4" to 3/4"**

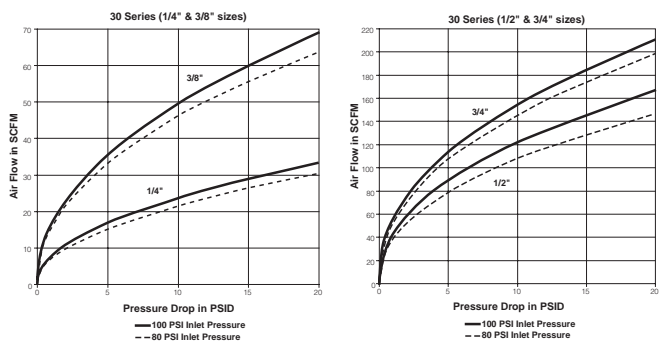

Female Pipe Thread

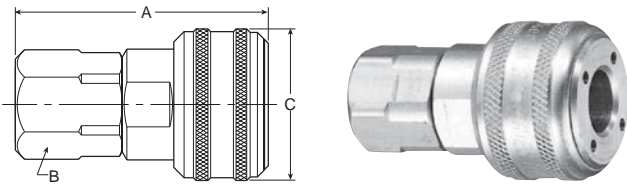

Body Size (Inches)	Part No. Brass	Thread Size	Overall Length A	Hex Size B	Largest Diameter C
1/4	B33A	1/8-27	1.96	0.75	1.20
1/4	B33	1/4-18	1.96	0.75	1.20
1/4	B33E	3/8-18	2.03	0.81	1.20
3/8	B35C	1/4-18	2.26	0.88	1.39
3/8	B35	3/8-18	2.33	0.88	1.39
3/8	B35F	1/2-14	2.57	1.00	1.39
1/2	B37E	3/8-18	2.76	1.00	1.52
1/2	B37	1/2-14	3.00	1.00	1.52
1/2	B37G	3/4-14	3.12	1.25	1.52
3/4	B39F	1/2-14	2.85	1.31	1.90
3/4	B39	3/4-14	2.99	1.31	1.90
3/4	B39J	1-11½	3.18	1.56	1.90

Standard Hose Barb

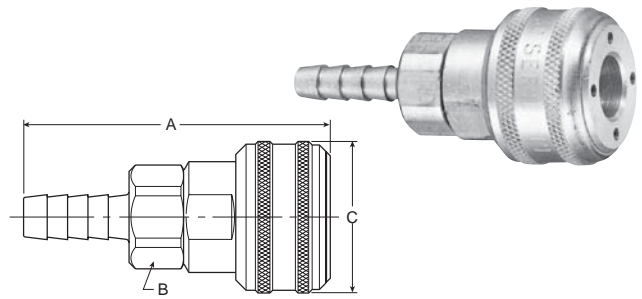

Body Size (Inches)	Part No. Brass	Hose I.D.	Overall Length A	Hex Size B	Largest Diameter C
1/4	B30-3B	1/4	2.62	0.75	1.20
1/4	B30-4B	5/16	2.62	0.75	1.20
1/4	B30-5B	3/8	2.62	0.75	1.20
3/8	B34-5B	3/8	2.85	0.88	1.39
3/8	B34-6B	1/2	2.85	0.88	1.39
1/2	B36-6B	1/2	3.33	1.00	1.52
1/2	B36-7B	3/4	3.86	1.00	1.52
3/4	B38-7B	3/4	3.69	1.31	1.90
3/4	B38-8B	1	3.93	1.31	1.90

Male Pipe Thread

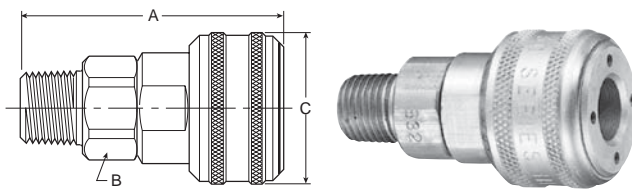

Body Size (Inches)	Part No. Brass	Thread Size	Overall Length A	Hex Size B	Largest Diameter C
1/4	B32A	1/8-27	2.03	0.75	1.20
1/4	B32	1/4-18	2.18	0.75	1.20
1/4	B32E	3/8-18	2.18	0.75	1.20
3/8	B34C	1/4-18	2.38	0.88	1.39
3/8	B34	3/8-18	2.44	0.88	1.39
3/8	B34F	1/2-14	2.57	0.88	1.39
1/2	B36E	3/8-18	2.92	1.00	1.52
1/2	B36	1/2-14	3.09	1.00	1.52
1/2	B36G	3/4-14	3.12	1.13	1.52
3/4	B38	3/4-14	2.95	1.31	1.90
3/4	B38J	1-11½	3.12	1.31	1.90

Push-Lok Hose Barb*

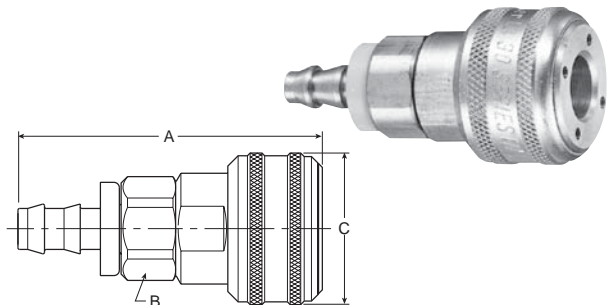

Body Size (Inches)	Part No. Brass	Hose I.D.	Overall Length A	Hex Size B	Largest Diameter C
1/4	B30-3BP	1/4	2.45	0.75	1.20
1/4	B30-5BP	3/8	2.60	0.75	1.20
3/8	B34-5BP	3/8	2.82	0.88	1.39
1/2	B36-6BP	1/2	3.46	1.00	1.52

* Push-Lok hose barbs are designed for use with push-lok hose and do not require clamps.

NOTE: To indicate Fluorocarbon seals, add the letter Y as a suffix to the catalog number of the coupler.
Example: B30-3BY

Repair Kits

Body Size	Nitrile	Fluorocarbon	Ethylene Propylene
1/4	21K	21KY	21KW
3/8	14K	14KY	14KW
1/2	16K	16KY	16KW
3/4	38K	38KY	38KW

NOTE: To indicate Fluorocarbon seals, add the letter Y as a suffix to the catalog number of the coupler. To indicate Ethylene Propylene seals, add the letter W as a suffix to the catalog number of the coupler.
Example: B33AY or B33AW

Description

Economat couplings feature the tubular valve in a coupler body that interchanges with ARO 210 and similar design couplers and nipples. Economat couplings are available only in 1/4" body size, but include 3/8" thread size. Economat couplings have brass bodies with steel sleeves and valves for durability. Standard seal material is Nitrile.

Specifications

Body Size: 1/4"

Rated Pressure: 300 psi

Temperature Range

(Standard Seals): -40°F to 250°F

Locking Device: 4 balls

**Couplers
Female Pipe Thread**

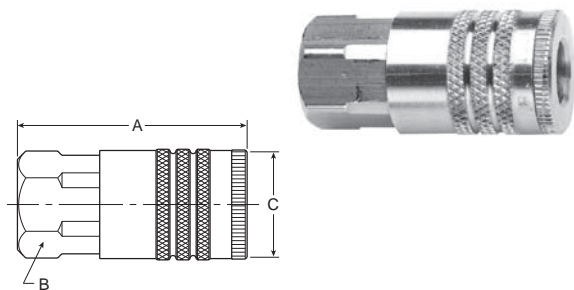

Body Size (Inches)	Part No. Brass	Thread Size	Overall Length A	Hex Size B	Largest Diameter C
1/4	B53	1/4-18 NPTF	1.83	0.75	0.90
1/4	B53E	3/8-18 NPTF	1.95	0.81	0.94

**Couplers
Push-Lok Hose Barb***

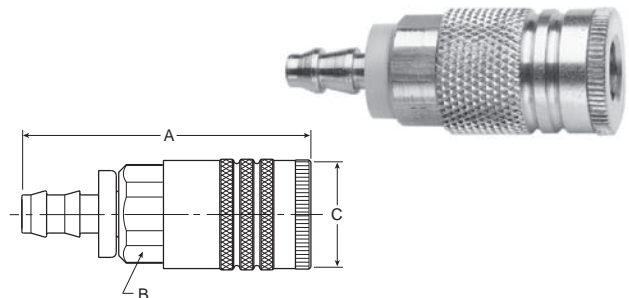

Body Size (Inches)	Part No. Brass	Hose I.D.	Overall Length A	Hex Size B	Largest Diameter C
1/4	B50-03BP	1/4	2.32	0.75	0.90
1/4	B50-05BP	3/8	2.47	0.75	0.90

* Push-Lok hose barbs are designed for use with push-lok hose and do not require clamps.

**Couplers
Male Pipe Thread**

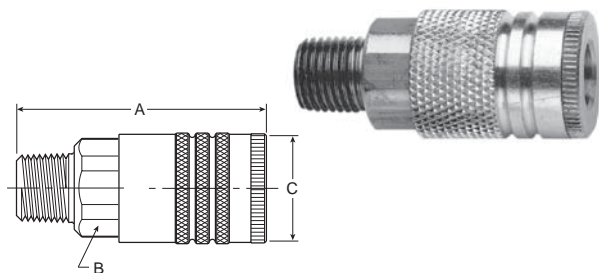

Body Size (Inches)	Part No. Brass	Thread Size	Overall Length A	Hex Size B	Largest Diameter C
1/4	B52	1/4-18	2.05	0.75	0.90
1/4	B52E	3/8-18	2.08	0.75	0.90

Flow Chart

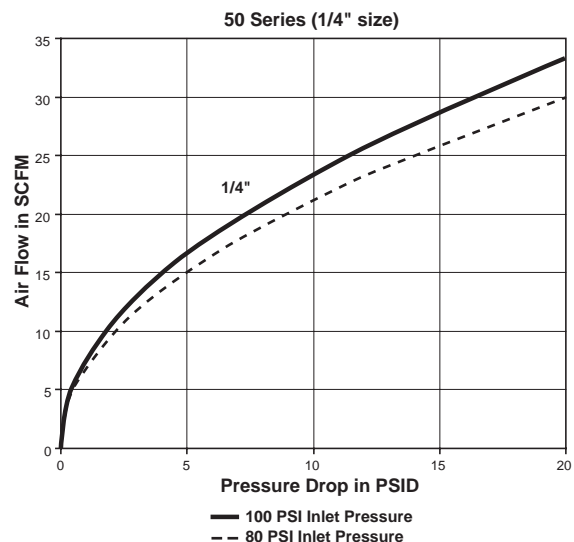

Nipples Female Pipe Thread

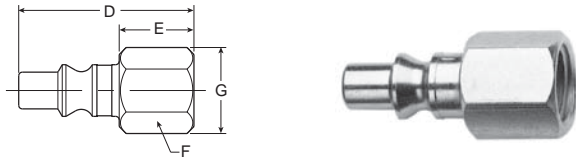

Body Size (Inches)	Part No. Steel	Thread Size	Overall Length D	Exposed Length* E	Hex Size F	Largest Diameter G
1/4	A3C	1/4-18	1.47	0.66	0.62	0.72

* This dimension represents portion of nipple that is exposed when nipple is inserted in coupler.

Nipples Standard Hose Barb

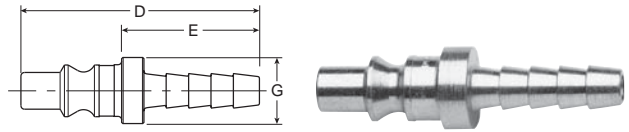

Body Size (Inches)	Part No. Steel	Hose I.D.	Overall Length D	Exposed Length* E	Largest Diameter G
1/4	A8C	1/4	1.63	0.85	0.43

* This dimension represents portion of nipple that is exposed when nipple is inserted in coupler.

Nipples Male Pipe Thread

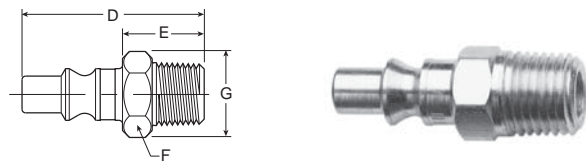

Body Size (Inches)	Part No. Steel	Thread Size	Overall Length D	Exposed Length* E	Hex Size F	Largest Diameter G
1/4	A2C	1/4-18	1.62	0.82	0.56	0.65

* This dimension represents portion of nipple that is exposed when nipple is inserted in coupler.

Nipples Push-Lok Hose Barb**

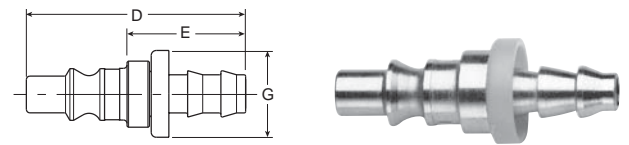

Body Size (Inches)	Part No. Steel	Hose I.D.	Overall Length D	Exposed Length* E	Largest Diameter G
1/4	A8CP	1/4	1.65	0.87	0.43

* This dimension represents portion of nipple that is exposed when nipple is inserted in coupler.

** Push-Lok barbs are designed for use with push-lok hose and do not require clamps.



Safety Guide For Selecting And Using Pneumatic Division Products And Related Accessories



WARNING:

FAILURE OR IMPROPER SELECTION OR IMPROPER USE OF PNEUMATIC DIVISION PRODUCTS, ASSEMBLIES OR RELATED ITEMS (“PRODUCTS”) CAN CAUSE DEATH, PERSONAL INJURY, AND PROPERTY DAMAGE. POSSIBLE CONSEQUENCES OF FAILURE OR IMPROPER SELECTION OR IMPROPER USE OF THESE PRODUCTS INCLUDE BUT ARE NOT LIMITED TO:

- Unintended or mistimed cycling or motion of machine members or failure to cycle
- Work pieces or component parts being thrown off at high speeds.
- Failure of a device to function properly for example, failure to clamp or unclamp an associated item or device.
- Explosion
- Suddenly moving or falling objects.
- Release of toxic or otherwise injurious liquids or gasses.

Before selecting or using any of these Products, it is important that you read and follow the instructions below.

1. GENERAL INSTRUCTIONS

- 1.1. Scope:** This safety guide is designed to cover general guidelines on the installation, use, and maintenance of Pneumatic Division Valves, FRLs (Filters pressure Regulators and Lubricators), Vacuum products and related accessory components.
- 1.2. Fail-Safe:** Valves, FRLs, Vacuum products and their related components can and do fail without warning for many reasons. Design all systems and equipment in a fail-safe mode, so that failure of associated valves, FRLs or Vacuum products will not endanger persons or property.
- 1.3 Relevant International Standards:** For a good guide to the application of a broad spectrum of pneumatic fluid power devices see: ISO 4414:1998, Pneumatic Fluid Power – General Rules Relating to Systems. See www.iso.org for ordering information.
- 1.4. Distribution:** Provide a copy of this safety guide to each person that is responsible for selection, installation, or use of Valves, FRLs or Vacuum products. Do not select, or use Watts valves, FRLs or vacuum products without thoroughly reading and understanding this safety guide as well as the specific Watts publications for the products considered or selected.
- 1.5. User Responsibility:** Due to the wide variety of operating conditions and applications for valves, FRLs, and vacuum products Watts and its distributors do not represent or warrant that any particular valve, FRL or vacuum product is suitable for any specific end use system. This safety guide does not analyze all technical parameters that must be considered in selecting a product. The user, through its own analysis and testing, is solely responsible for:
 - Making the final selection of the appropriate valve, FRL, Vacuum component, or accessory.
 - Assuring that all user's performance, endurance, maintenance, safety, and warning requirements are met and that the application presents no health or safety hazards.
 - Complying with all existing warning labels and / or providing all appropriate health and safety warnings on the equipment on which the valves, FRLs or Vacuum products are used; and,
 - Assuring compliance with all applicable government and industry standards.
- 1.6. Safety Devices:** Safety devices should not be removed, or defeated.
- 1.7. Warning Labels:** Warning labels should not be removed, painted over or otherwise obscured.
- 1.8. Additional Questions:** Call the appropriate Watts technical service department if you have any questions or require any additional information. See the Watts publication for the product being considered or used, or call 269-629-5000, or go to www.wattsfluidair.com, for telephone numbers of the appropriate technical service department.

2. PRODUCT SELECTION INSTRUCTIONS

- 2.1. Flow Rate:** The flow rate requirements of a system are frequently the primary consideration when designing any pneumatic system. System components need to be able to provide adequate flow and pressure for the desired application.
- 2.2. Pressure Rating:** Never exceed the rated pressure of a product. Consult product labeling, Pneumatic Division catalogs or the instruction sheets supplied for maximum pressure ratings.
- 2.3. Temperature Rating:** Never exceed the temperature rating of a product. Excessive heat can shorten the life expectancy of a product and result in complete product failure.
- 2.4. Environment:** Many environmental conditions can affect the integrity and suitability of a product for a given application. Pneumatic Division products are designed for use in general purpose industrial applications. If these products are to be used in unusual circumstances such as direct sunlight and/or corrosive or caustic environments, such use can shorten the useful life and lead to premature failure of a product.
- 2.5. Lubrication and Compressor Carryover:** Some modern synthetic oils can and will attack nitrile seals. If there is any possibility of synthetic oils or greases migrating into the pneumatic components check for compatibility with the seal materials used. Consult the factory or product literature for materials of construction.
- 2.6. Polycarbonate Bowls and Sight Glasses:** To avoid potential polycarbonate bowl failures:
 - Do not locate polycarbonate bowls or sight glasses in areas where they could be subject to direct sunlight, impact blow, or temperatures outside of the rated range.
 - Do not expose or clean polycarbonate bowls with detergents, chlorinated hydro-carbons, ketones, esters or certain alcohols.
 - Do not use polycarbonate bowls or sight glasses in air systems where compressors are lubricated with fire resistant fluids such as phosphate ester and di-ester lubricants.

Safety Guide

2.7. Chemical Compatibility: For more information on plastic component chemical compatibility see Pneumatic Division technical bulletins Tec-3, Tec-4, and Tec-5

2.8. Product Rupture: Product rupture can cause death, serious personal injury, and property damage.

- Do not connect pressure regulators or other Pneumatic Division products to bottled gas cylinders.
- Do not exceed the maximum primary pressure rating of any pressure regulator or any system component.
- Consult product labeling or product literature for pressure rating limitations.

3. PRODUCT ASSEMBLY AND INSTALLATION INSTRUCTIONS

3.1. Component Inspection: Prior to assembly or installation a careful examination of the valves, FRLs or vacuum products must be performed. All components must be checked for correct style, size, and catalog number. DO NOT use any component that displays any signs of nonconformance.

3.2. Installation Instructions: Watts published Installation Instructions must be followed for installation of Watts valves, FRLs and vacuum components. These instructions are provided with every Watts valve or FRL sold, or by calling 269-629-5000, or at www.wattsfluidair.com.

3.3. Air Supply: The air supply or control medium supplied to Valves, FRLs and Vacuum components must be moisture-free if ambient temperature can drop below freezing

4. VALVE AND FRL MAINTENANCE AND REPLACEMENT INSTRUCTIONS

4.1. Maintenance: Even with proper selection and installation, valve, FRL and vacuum products service life may be significantly reduced without a continuing maintenance program. The severity of the application, risk potential from a component failure, and experience with any known failures in the application or in similar applications should determine the frequency of inspections and the servicing or replacement of Pneumatic Division products so that products are replaced before any failure occurs. A maintenance program must be established and followed by the user and, at minimum, must include instructions 4.2 through 4.10.

4.2. Installation and Service Instructions: Before attempting to service or replace any worn or damaged parts consult the appropriate Service Bulletin for the valve or FRL in question for the appropriate practices to service the unit in question. These Service and Installation Instructions are provided with every Watts valve and FRL sold, or are available by calling 269-629-5000, or by accessing the Watts web site at www.wattsfluidair.com.

4.3. Lockout / Tagout Procedures: Be sure to follow all required lockout and tagout procedures when servicing equipment. For more information see: OSHA Standard – 29 CFR, Part 1910.147, Appendix A, The Control of Hazardous Energy – (Lockout / Tagout)

4.4. Visual Inspection: Any of the following conditions requires immediate system shut down and replacement of worn or damaged components:

- Air leakage: Look and listen to see if there are any signs of visual damage to any of the components in the system. Leakage is an indication of worn or damaged components.
- Damaged or degraded components: Look to see if there are any visible signs of wear or component degradation.
- Kinked, crushed, or damaged hoses. Kinked hoses can result in restricted air flow and lead to unpredictable system behavior.
- Any observed improper system or component function: Immediately shut down the system and correct malfunction.
- Excessive dirt build-up: Dirt and clutter can mask potentially hazardous situations.

Caution: Leak detection solutions should be rinsed off after use.

4.5. Routine Maintenance Issues:

- Remove excessive dirt, grime and clutter from work areas.
- Make sure all required guards and shields are in place.

4.6. Functional Test: Before initiating automatic operation, operate the system manually to make sure all required functions operate properly and safely.

4.7. Service or Replacement Intervals: It is the user's responsibility to establish appropriate service intervals. Valves, FRLs and vacuum products contain components that age, harden, wear, and otherwise deteriorate over time. Environmental conditions can significantly accelerate this process. Valves, FRLs and vacuum components need to be serviced or replaced on routine intervals. Service intervals need to be established based on:

- Previous performance experiences.
- Government and / or industrial standards.
- When failures could result in unacceptable down time, equipment damage or personal injury risk.

4.8. Servicing or Replacing of any Worn or Damaged Parts: To avoid unpredictable system behavior that can cause death, personal injury and property damage:

- Follow all government, state and local safety and servicing practices prior to service including but not limited to all OSHA Lockout Tagout procedures (OSHA Standard – 29 CFR, Part 1910.147, Appendix A, The Control of Hazardous Energy – Lockout / Tagout).
- Disconnect electrical supply (when necessary) before installation, servicing, or conversion.
- Disconnect air supply and depressurize all air lines connected to system and Pneumatic Division products before installation, service, or conversion.
- Installation, servicing, and / or conversion of these products must be performed by knowledgeable personnel who understand how pneumatic products are to be applied.
- After installation, servicing, or conversions air and electrical supplies (when necessary) should be connected and the product tested for proper function and leakage. If audible leakage is present, or if the product does not operate properly, do not put product or system into use.
- Warnings and specifications on the product should not be covered or painted over. If masking is not possible, contact your local representative for replacement labels.

4.9. Putting Serviced System Back into Operation: Follow the guidelines above and all relevant Installation and Maintenance Instructions supplied with the valve FRL or vacuum component to insure proper function of the system.

The items described in this document and other documents and descriptions provided by Parker Hannifin Corporation, its subsidiaries and its authorized distributors ("Seller") are hereby offered for sale at prices to be established by Seller. This offer and its acceptance by any customer ("Buyer") shall be governed by all of the following Terms and Conditions. Buyer's order for any item described in its document, when communicated to Seller verbally, or in writing, shall constitute acceptance of this offer. All goods or work described will be referred to as "Products".

1. Terms and Conditions. Seller's willingness to offer Products, or accept an order for Products, to or from Buyer is expressly conditioned on Buyer's assent to these Terms and Conditions and to the terms and conditions found on-line at www.parker.com/saleterms/. Seller objects to any contrary or additional term or condition of Buyer's order or any other document issued by Buyer.

2. Price Adjustments; Payments. Prices stated on the reverse side or preceding pages of this document are valid for 30 days. After 30 days, Seller may change prices to reflect any increase in its costs resulting from state, federal or local legislation, price increases from its suppliers, or any change in the rate, charge, or classification of any carrier. The prices stated on the reverse or preceding pages of this document do not include any sales, use, or other taxes unless so stated specifically. Unless otherwise specified by Seller, all prices are F.O.B. Seller's facility, and payment is due 30 days from the date of invoice. After 30 days, Buyer shall pay interest on any unpaid invoices at the rate of 1.5% per month or the maximum allowable rate under applicable law.

3. Delivery Dates; Title and Risk; Shipment. All delivery dates are approximate and Seller shall not be responsible for any damages resulting from any delay. Regardless of the manner of shipment, title to any products and risk of loss or damage shall pass to Buyer upon tender to the carrier at Seller's facility (i.e., when it's on the truck, it's yours). Unless otherwise stated, Seller may exercise its judgment in choosing the carrier and means of delivery. No deferral of shipment at Buyers' request beyond the respective dates indicated will be made except on terms that will indemnify, defend and hold Seller harmless against all loss and additional expense. Buyer shall be responsible for any additional shipping charges incurred by Seller due to Buyer's changes in shipping, product specifications or in accordance with Section 13, herein.

4. Warranty. Seller warrants that the Products sold hereunder shall be free from defects in material or workmanship for a period of twelve months from the date of delivery to Buyer or 2,000 hours of normal use, whichever occurs first. This warranty is made only to Buyer and does not extend to anyone to whom Products are sold after purchased from Seller. The prices charged for Seller's products are based upon the exclusive limited warranty stated above, and upon the following disclaimer: **DISCLAIMER OF WARRANTY: THIS WARRANTY COMPRISES THE SOLE AND ENTIRE WARRANTY PERTAINING TO PRODUCTS PROVIDED HEREUNDER. SELLER DISCLAIMS ALL OTHER WARRANTIES, EXPRESS AND IMPLIED, INCLUDING MERCHANTABILITY AND FITNESS FOR A PARTICULAR PURPOSE.**

5. Claims; Commencement of Actions. Buyer shall promptly inspect all Products upon delivery. No claims for shortages will be allowed unless reported to the Seller within 10 days of delivery. No other claims against Seller will be allowed unless asserted in writing within 60 days after delivery or, in the case of an alleged breach of warranty, within 30 days after the date within the warranty period on which the defect is or should have been discovered by Buyer. Any action based upon breach of this agreement or upon any other claim arising out of this sale (other than an action by Seller for any amount due to Seller from Buyer) must be commenced within thirteen months from the date of tender of delivery by Seller or, for a cause of action based upon an alleged breach of warranty, within thirteen months from the date within the warranty period on which the defect is or should have been discovered by Buyer.

6. LIMITATION OF LIABILITY. UPON NOTIFICATION, SELLER WILL, AT ITS OPTION, REPAIR OR REPLACE A DEFECTIVE PRODUCT, OR REFUND THE PURCHASE PRICE. IN NO EVENT SHALL SELLER BE LIABLE TO BUYER FOR ANY SPECIAL, INDIRECT, INCIDENTAL OR CONSEQUENTIAL DAMAGES ARISING OUT OF, OR AS THE RESULT OF, THE SALE, DELIVERY, NON-DELIVERY, SERVICING, USE OR LOSS OF USE OF THE PRODUCTS OR ANY PART THEREOF, OR FOR ANY CHARGES OR EXPENSES OF ANY NATURE INCURRED WITHOUT SELLER'S WRITTEN CONSENT, EVEN IF SELLER HAS BEEN NEGLIGENT, WHETHER IN CONTRACT, TORT OR OTHER LEGAL THEORY. IN NO EVENT SHALL SELLER'S LIABILITY UNDER ANY CLAIM MADE BY BUYER EXCEED THE PURCHASE PRICE OF THE PRODUCTS.

7. Contingencies. Seller shall not be liable for any default or delay in performance if caused by circumstances beyond the reasonable control of Seller.

8. User Responsibility. The user, through its own analysis and testing, is solely responsible for making the final selection of the system and Product and assuring that all performance, endurance, maintenance, safety and warning requirements of the application are met. The user must analyze all aspects of the application and follow applicable industry standards and Product information. If Seller provides Product or system options, the user is responsible for determining that such data and specifications are suitable and sufficient for all applications and reasonably foreseeable uses of the Products or systems.

9. Loss to Buyer's Property. Any designs, tools, patterns, materials, drawings, confidential information or equipment furnished by Buyer or any other items which become Buyer's property, may be considered obsolete and may be destroyed by Seller after two consecutive years have elapsed without Buyer placing an order for the items which are manufactured using such property. Seller shall not be responsible for any loss or damage to such property while it is in Seller's possession or control.

10. Special Tooling. A tooling charge may be imposed for any special tooling, including without limitation, dies, fixtures, molds and patterns, acquired to manufacture Products. Such special tooling shall be and remain Seller's property notwithstanding payment of any charges by Buyer. In no event will Buyer acquire any interest in apparatus belonging to Seller which is utilized in the manufacture of the Products, even if such apparatus has been specially converted or adapted for such manufacture and notwithstanding any charges paid by Buyer. Unless otherwise agreed, Seller shall have the right to alter, discard or otherwise dispose of any special tooling or other property in its sole discretion at any time.

11. Buyer's Obligation; Rights of Seller. To secure payment of all sums due or otherwise, Seller shall retain a security interest in the goods delivered and this agreement shall be deemed a Security Agreement under the Uniform Commercial Code. Buyer authorizes Seller as its attorney to execute and file on Buyer's behalf all documents Seller deems necessary to perfect its security interest. Seller shall have a security interest in, and lien upon, any property of Buyer in Seller's possession as security for the payment of any amounts owed to Seller by Buyer.

12. Improper use and Indemnity. Buyer shall indemnify, defend, and hold Seller harmless from any claim, liability, damages, lawsuits, and costs (including attorney fees), whether for personal injury, property damage, patent, trademark or copyright infringement or any other claim, brought by or incurred by Buyer, Buyer's employees, or any other person, arising out of: (a) improper selection, improper application or other misuse of Products purchased by Buyer from Seller; (b) any act or omission, negligent or otherwise, of Buyer; (c) Seller's use of patterns, plans, drawings, or specifications furnished by Buyer to manufacture Product; or (d) Buyer's failure to comply with these terms and conditions. Seller shall not indemnify Buyer under any circumstance except as otherwise provided.

13. Cancellations and Changes. Orders shall not be subject to cancellation or change by Buyer for any reason, except with Seller's written consent and upon terms that will indemnify, defend and hold Seller harmless against all direct, incidental and consequential loss or damage. Seller may change product features, specifications, designs and availability with notice to Buyer.

14. Limitation on Assignment. Buyer may not assign its rights or obligations under this agreement without the prior written consent of Seller.

15. Entire Agreement. This agreement contains the entire agreement between the Buyer and Seller and constitutes the final, complete and exclusive expression of the terms of the agreement. All prior or contemporaneous written or oral agreements or negotiations with respect to the subject matter are herein merged.

16. Waiver and Severability. Failure to enforce any provision of this agreement will not waive that provision nor will any such failure prejudice Seller's right to enforce that provision in the future. Invalidation of any provision of this agreement by legislation or other rule of law shall not invalidate any other provision herein. The remaining provisions of this agreement will remain in full force and effect.

17. Termination. This agreement may be terminated by Seller for any reason and at any time by giving Buyer thirty (30) days written notice of termination. In addition, Seller may by written notice immediately terminate this agreement for the following: (a) Buyer commits a breach of any provision of this agreement (b) the appointment of a trustee, receiver or custodian for all or any part of Buyer's property (b) the filing of a petition for relief in bankruptcy of the other Party on its own behalf, or by a third party (c) an assignment for the benefit of creditors, or (d) the dissolution or liquidation of the Buyer.

18. Governing Law. This agreement and the sale and delivery of all Products hereunder shall be deemed to have taken place in and shall be governed and construed in accordance with the laws of the State of Ohio, as applicable to contracts executed and wholly performed therein and without regard to conflicts of laws principles. Buyer irrevocably agrees and consents to the exclusive jurisdiction and venue of the courts of Cuyahoga County, Ohio with respect to any dispute, controversy or claim arising out of or relating to this agreement. Disputes between the parties shall not be settled by arbitration unless, after a dispute has arisen, both parties expressly agree in writing to arbitrate the dispute.

19. Indemnity for Infringement of Intellectual Property Rights. Seller shall have no liability for infringement of any patents, trademarks, copyrights, trade dress, trade secrets or similar rights except as provided in this Section. Seller will defend and indemnify Buyer against allegations of infringement of U.S. patents, U.S. trademarks, copyrights, trade dress and trade secrets ("Intellectual Property Rights"). Seller will defend at its expense and will pay the cost of any settlement or damages awarded in an action brought against Buyer based on an allegation that a Product sold pursuant to this Agreement infringes the Intellectual Property Rights of a third party. Seller's obligation to defend and indemnify Buyer is contingent on Buyer notifying Seller within ten (10) days after Buyer becomes aware of such allegations of infringement, and Seller having sole control over the defense of any allegations or actions including all negotiations for settlement or compromise. If a Product is subject to a claim that it infringes the Intellectual Property Rights of a third party, Seller may, at its sole expense and option, procure for Buyer the right to continue using the Product, replace or modify the Product so as to make it noninfringing, or offer to accept return of the Product and return the purchase price less a reasonable allowance for depreciation. Notwithstanding the foregoing, Seller shall have no liability for claims of infringement based on information provided by Buyer, or directed to Products delivered hereunder for which the designs are specified in whole or part by Buyer, or infringements resulting from the modification, combination or use in a system of any Product sold hereunder. The foregoing provisions of this Section shall constitute Seller's sole and exclusive liability and Buyer's sole and exclusive remedy for infringement of Intellectual Property Rights.

20. Taxes. Unless otherwise indicated, all prices and charges are exclusive of excise, sales, use, property, occupational or like taxes which may be imposed by any taxing authority upon the manufacture, sale or delivery of Products.

21. Equal Opportunity Clause. For the performance of government contracts and where dollar value of the Products exceed \$10,000, the equal employment opportunity clauses in Executive Order 11246, VEVRAA, and 41 C.F.R. §§ 60-1.4(a), 60-741.5(a), and 60-250.4, are hereby incorporated.