 **WARNING**

To avoid unpredictable system behavior that can cause personal injury and property damage:

- Disconnect electrical supply (when necessary) before installation, servicing, or conversion.
- Disconnect air supply and depressurize all air lines connected to this product before installation, servicing, or conversion.
- Operate within the manufacturer's specified pressure, temperature, and other conditions listed in these instructions.
- Medium must be moisture-free if ambient temperature is below freezing.
- Service according to procedures listed in these instructions.
- Installation, service, and conversion of these products must be performed by knowledgeable personnel who understand how pneumatic products are to be applied.
- After installation, servicing, or conversion, air and electrical supplies (when necessary) should be connected and the product tested for proper function and leakage. If audible leakage is present, or the product does not operate properly, do not put into use.
- Warnings and specifications on the product should not be covered by paint, etc. If masking is not possible, contact your local representative for replacement labels.

 **CAUTION**

Polyurethane bowls, being transparent and tough, are ideal for use with Filters and Lubricators. They are suitable for use in normal industrial environments, but should not be located in areas where they could be subjected to direct sunlight, an impact blow, nor temperatures outside of the rated range. As with most plastics, some chemicals can cause damage. Polyurethane bowls should not be exposed to chlorinated hydrocarbons, ketones, esters and certain alcohols. They should not be used in air systems where compressors are lubricated with fire-resistant fluids such as phosphate ester and di-ester types.

Metal bowls are recommended where ambient and/or media conditions are not compatible with polyurethane bowls. Metal bowls resist the action of most such solvents, but should not be used where strong acids or bases are present or in salt laden atmospheres. Consult the factory for specific recommendations where these conditions exist.

TO CLEAN POLYURETHANE BOWLS USE MILD SOAP AND WATER ONLY! DO NOT use cleansing agents such as acetone, benzene, carbon tetrachloride, gasoline, toluene, etc., which are damaging to this plastic.

Bowl guards are recommended for added protection of polyurethane bowls where chemical attack may occur.

Introduction

Follow these instructions when installing, operating, or servicing the product.

Application Limits

These products are intended for use with compressed air in industrial applications. For other applications, consult factory before use.

Maximum Recommended Pressure Drop:

	kPa	PSIG	bar
Coalescing Filter	70	10	0.7

With Polyurethane Bowl with Polypropylene Bowl Guard

	kPa	PSIG	bar
Operating Pressure Maximum	1034	150	10
Operating Temperature Range	4°C to 52°C (40°F to 125°F)		

With Metal Bowl

	kPa	PSIG	bar
Operating Pressure Maximum	2068	300	21
Operating Temperature Range	4°C to 82°C (40°F to 180°F)		

With Metal Bowl with Wrap Around Sight Gauge

	kPa	PSIG	bar
Operating Pressure Maximum	1723	250	17
Operating Temperature Range	4°C to 66°C (40°F to 150°F)		

ANSI Symbols

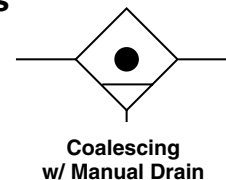

Installation

To protect against premature filter cartridge replacement, blow out scale and other foreign matter from pipe line before installation. It is also recommended that a prefilter be installed, upstream of the coalescing filter, to remove 40 micron and larger size particles from the air line. Install coalescing filter with bowl vertical to pipe line, with proper orientation of flow arrows on body.

Maintenance

Never let the liquid level in bowl reach the base of filter element. Because of high degree of water and oil removal efficiency, it is recommended that an SA602MD-M4 auto drain be used to automatically drain bowl.

During operation, a dark band will be noticed around the base of the element which is normal. If dark spots are noticed on the upper portion of the foam covering, excessive liquid is being removed from the system and a prefilter should be installed.

The filter element should be replaced when pressure drop across the filter (within prescribed flow range) exceeds 10 PSI. This occurrence indicates that solid particles, which are trapped in the filter media, have reached a level such that air flow is restricted and efficiency deteriorates.

When replacing the filter element, turn bottom adapter counterclockwise to remove it from retaining rod and remove the old element. Handle the replacement by the ends as much as possible, install it between the top and bottom adapters and hand tighten the assembly. If the retaining rod turns out of the body during disassembly, the replacement element should be installed between the adapters as described above. Ensure the gasket is assembled between the top adapter and the body.

F31 Filter

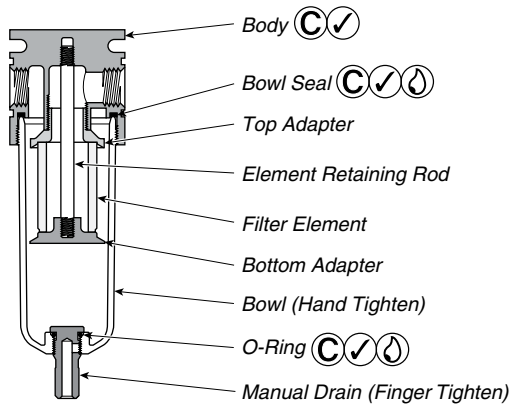

F51 Filter

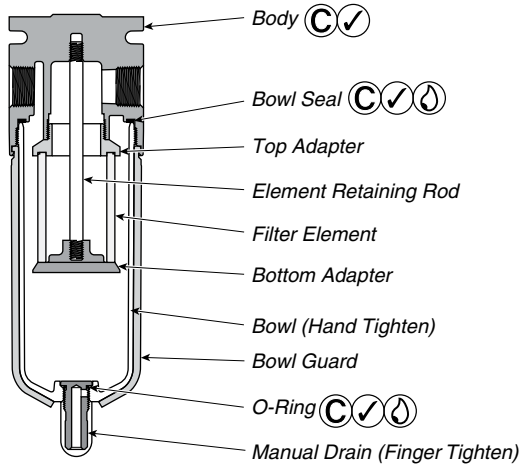

F101 Filter

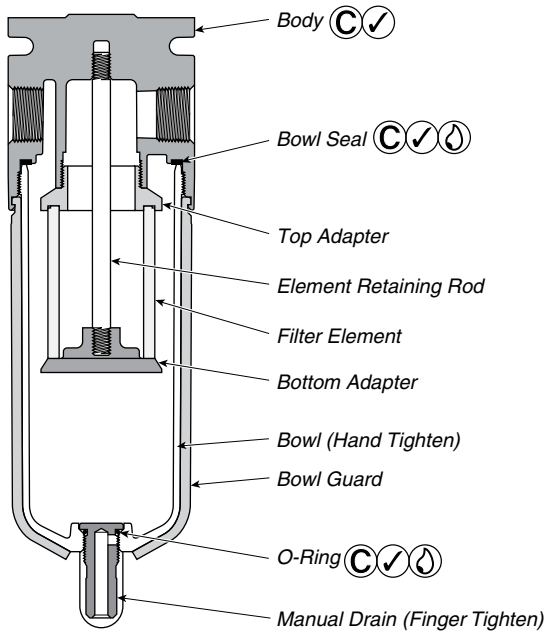

Cleaning

Blow out filter with air hose. **Clean bowl assembly with household soap only.** The auto drain may be flushed out manually by rotating the drain cock clockwise. If additional cleaning is required, remove the auto drain assembly from the filter bowl and clean screen. Disassemble the lever actuation mechanism by snapping lever out of the plastic retainer on Float and remove the Pin. Remove the Disc Assembly and the large Float. Carefully break away the interface fit between the black plastic Housing and the brass Body. Remove the Piston and Spring. Clean all component parts thoroughly with soapy water or alcohol, and clean or replace all seals as necessary. Ensure that the small orifices in the Housing and the Piston are not clogged. Carefully reassemble all parts, positioning them as shown on the reverse side of this instruction sheet.

Service Kits / Parts Available

Description	F31	F51	F101
Bowl Replacement Kits*			
Polyurethane w/Polypropylene Bowl Guard, 150 PSI Maximum Pressure	BKF35A	BKF55B	BKF105B
Zinc Bowl, 300 PSI Max. Pressure	BKF35D	BKF55D	BKF105D
Zinc Bowl w/Wraparound Sight Gauge, 250 PSI Maximum Pressure	BKF35W	BKF55W	BKF105W
Element Replacement Kits			
Activated Carbon	EKF31A	EKF51A	EKF101A
Coalescing	EKF31H	EKF51	EKF101
Piston Drain (Optional)	RK504SY	—	—
Repair Kit for All Internal Auto Drains	—	RK602MD/M4	

Auto Drain

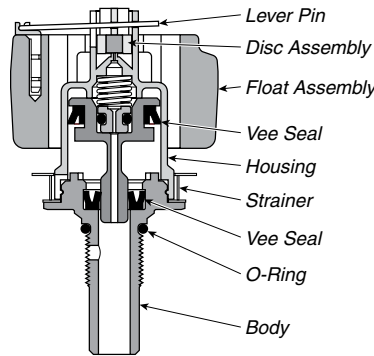

Piston Drain

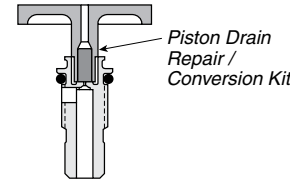

- Lightly grease with provided lubricant.
- Inspect for nicks, scratches, and surface imperfections. If present, reduced service life is probable and future replacement should be planned.
- Clean with lint-free cloth.

WARNING

FAILURE OR IMPROPER SELECTION OR IMPROPER USE OF THE PRODUCTS AND/OR SYSTEMS DESCRIBED HEREIN OR RELATED ITEMS CAN CAUSE DEATH, PERSONAL INJURY AND PROPERTY DAMAGE.

This document and other information from The Company, its subsidiaries and authorized distributors provide product and/or system options for further investigation by users having technical expertise. It is important that you analyze all aspects of your application, including consequences of any failure and review the information concerning the product or systems in the current product catalog. Due to the variety of operating conditions and applications for these products or systems, the user, through its own analysis and testing, is solely responsible for making the final selection of the products and systems and assuring that all performance, safety and warning requirements of the application are met.

The products described herein, including without limitation, product features, specifications, designs, availability and pricing, are subject to change by The Company and its subsidiaries at any time without notice.

EXTRA COPIES OF THESE INSTRUCTIONS ARE AVAILABLE FOR INCLUSION IN EQUIPMENT / MAINTENANCE MANUALS THAT UTILIZE THESE PRODUCTS. CONTACT YOUR LOCAL REPRESENTATIVE.