

! WARNING

To avoid unpredictable system behavior that can cause personal injury and property damage:

- Disconnect electrical supply (when necessary) before installation, servicing, or conversion.
- Disconnect air supply and depressurize all air lines connected to this product before installation, servicing, or conversion.
- Operate within the manufacturer's specified pressure, temperature, and other conditions listed in these instructions.
- Medium must be moisture-free if ambient temperature is below freezing.
- Service according to procedures listed in these instructions.
- Installation, service, and conversion of these products must be performed by knowledgeable personnel who understand how pneumatic products are to be applied.
- After installation, servicing, or conversion, air and electrical supplies (when necessary) should be connected and the product tested for proper function and leakage. If audible leakage is present, or the product does not operate properly, do not put into use.
- Warnings and specifications on the product should not be covered by paint, etc. If masking is not possible, contact your local representative for replacement labels.

! WARNING

Product rupture can cause serious injury.
Do not connect regulator to bottled gas.
Do not exceed maximum primary pressure rating.

Safety Guide

For more complete information on recommended application guidelines, see the Safety Guide section of Pneumatic Division catalogs or you can download the **Pneumatic Division Safety Guide** at: www.parker.com/pneumatics

! CAUTION

Polyurethane bowls, sight glass and sight domes on these units may be attacked by certain chemicals. Never use solvents like carbon tetrachloride, trichlorethylene, acetone, or paint thinner to clean any parts. These elements can cause crazing or failure of the plastic parts. The polyurethane resin parts are compatible with most hydrocarbon based synthetic lubricants but, before using, check with the manufacturer of the lubricant or oil for compatibility with polyurethane resin.

TO CLEAN POLYURETHANE BOWLS USE MILD SOAP AND WATER ONLY!

Introduction

Follow these instructions when installing, operating, or servicing the product.

Application Limits

These products are intended for use in general purpose compressed air systems only.

Maximum Recommended Pressure Drop:

	kPa	PSIG	bar
Particulate Filter	70	10	0.7

Operating Pressure Maximum

	kPa	PSIG	bar
Polycarbonate Bowl	1034	150	10.0
Metal Bowl	2068	300	21.0
Metal Bowl with Sight Gauge	1724	250	17.0
Metal Bowl with Piston Drain	1207	175	12.0

Operating Temperature Range

Polycarbonate Bowl	4°C to 49°C (40°F to 120°F)
Metal Bowl	4°C to 82°C (40°F to 180°F)
Metal Bowl with Sight Gauge	4°C to 66°C (40°F to 150°F)
Metal Bowl with Piston Drain	4°C to 66°C (40°F to 150°F)

Symbols

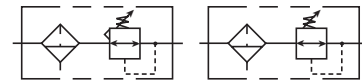

Filter / Regulator

Installation

1. The Filter / Regulator should be installed with reasonable accessibility for service whenever possible – repair service kits are available. Keep pipe or tubing lengths to a minimum with inside clean and free of dirt and chips. Pipe joint compound should be used sparingly and applied only to the male pipe – never into the female port. Do not use PTFE tape to seal pipe joints – pieces have a tendency to break off and lodge inside the unit, possibly causing malfunction. Also, new pipe or hose should be installed between the Filter / Regulator and equipment being protected.
2. The upstream pipe work must be clear of accumulated dirt and liquids.
3. Select a Filter / Regulator location as close as possible to the equipment being protected.
4. Install Filter / Regulator so that air flows in direction of arrow on top of body.
5. Install Filter / Regulator vertically with the bowl drain mechanism at the bottom. Free moisture will thus drain into the sump (“quiet zone”) at the bottom of the bowl.
6. Gauge ports are located on both sides of the Filter / Regulator body for your convenience. It is necessary to install a gauge or socket pipe plugs into each port during installation.

Operation

1. Both free moisture and solids are removed automatically by the filter.
2. Manual drain filters must be drained regularly before the separated moisture and oil reaches the bottom of the Baffle or End Cap.
3. The Filter Element should be removed and replaced when pressure differential across the filter is 69 kPa (10 PSIG).

! WARNING

FAILURE OR IMPROPER SELECTION OR IMPROPER USE OF THE PRODUCTS AND/OR SYSTEMS DESCRIBED HEREIN OR RELATED ITEMS CAN CAUSE DEATH, PERSONAL INJURY AND PROPERTY DAMAGE.

This document and other information from The Company, its subsidiaries and authorized distributors provide product and/or system options for further investigation by users having technical expertise. It is important that you analyze all aspects of your application, including consequences of any failure and review the information concerning the product or systems in the current product catalog. Due to the variety of operating conditions and applications for these products or systems, the user, through its own analysis and testing, is solely responsible for making the final selection of the products and systems and assuring that all performance, safety and warning requirements of the application are met.

The products described herein, including without limitation, product features, specifications, designs, availability and pricing, are subject to change by The Company and its subsidiaries at any time without notice.

EXTRA COPIES OF THESE INSTRUCTIONS ARE AVAILABLE FOR INCLUSION IN EQUIPMENT / MAINTENANCE MANUALS THAT UTILIZE THESE PRODUCTS. CONTACT YOUR LOCAL REPRESENTATIVE.

- Before turning on the air supply, disengage the Adjusting Knob by pulling upward. Turn Adjusting Knob counterclockwise until the compression is released from the Pressure Control Spring.
- Then turn Knob clockwise and adjust regulator to desired downstream pressure. This permits pressure to build up slowly in the downstream line.
- To decrease regulated pressure settings, always reset from a pressure lower than the final setting required. Example, lowering the secondary pressure from 550 to 410 kPa (80 to 60 PSIG) is best accomplished by dropping the secondary pressure to 350 kPa (50 PSIG), then adjusting upward to 410 kPa (60 PSIG).
- When desired secondary pressure settings have been reached, push the Knob down to lock this pressure setting.

Service

⚠ Caution: Disconnect or shut off air supply and exhaust the primary and secondary pressures before servicing unit. Turning the Adjusting Knob counterclockwise does not vent downstream pressure on non-relieving regulators. Downstream pressure must be vented before servicing regulator.

⚠ Caution: Grease packets are supplied with kits for lubrication of seals. Use only mineral based grease or oils. Do not use synthetic oils such as esters. Do not use silicones.

Note: After servicing unit, turn on air supply and adjust regulator to the desired downstream pressure. Check unit for leaks. If leakage occurs, do not operate - conduct repairs and retest.

Servicing Filter Element - (Refer to Figure 1)

- Unscrew and remove Bowl.
- Unscrew the Element Retainer from Body and then remove Deflector and Element.
- Clean all internal parts and bowl before reassembling.
- Install new element. Install Deflector. **IMPORTANT:** The Filter / Regulator will not operate properly if the Deflector is not installed properly.
- Attach Element Retainer and finger tighten firmly.
- Replace Bowl Seal. Lightly lubricate new seal to assist with retaining it in position.
- Install Bowl into Body and tighten; hand tight, plus 1/4 turn.

Servicing Regulator - (Refer to Figure 1)

- Disengage the Adjusting Knob by pulling upward. Turn Adjusting Knob counterclockwise until the compression is released from the Pressure Control Spring.
- Remove the Bonnet and Bowl assemblies by unscrewing the Bonnet and Bowl from the Body.
- Remove Diaphragm Assembly and Slip Ring from Body.
- Remove Element Retainer, Deflector, Filter Element, Poppet Assembly, Poppet Return Spring.
- Clean and carefully inspect parts for wear or damage. Wipe parts, clean with soapy water or denatured alcohol **but do not use denatured alcohol on plastic bowl or sight gauge.** If using compressed air to blow dry, be sure to wear appropriate eye protection. If replacement is necessary, use parts from service kits. Clean Bowl.
- Lubricate O-rings with grease found in service kits.
- Install Filter Element onto the Filter Retainer, and install Deflector onto Retainer.
- Install Poppet Assembly, Poppet Return Spring, Element Retainer and Element. **IMPORTANT:** The Filter / Regulator will not operate properly if the Deflector is not installed properly.
- Install Diaphragm Assembly and Slip Ring into Body Assembly. Assemble Bonnet Assembly onto Body and tighten per Figure 1.
- Install Bowl into Body and tighten, hand tight, plus 1/4 turn.

Combination Unit Assembly

To assemble units in combination, use AK105 Combination Assembly Kit. Liberally apply grease to the o-ring and insert into the o-ring groove on the filter "outlet" face or the lubricator "inlet" face. Regulator may be mounted in either up or down position, but not sideways. Insert assembly screws in through slots in the body of the filter or lubricator and into tapped holes on regulator mounting face. Position parts with mounting slots aligned, and tighten screws slightly more than hand tight. Units are easily disassembled

in reverse order of above procedure. End plates and diverter block may be assembled in the same manner as described above, with the o-ring in the appropriate groove and the screws through the slots. Note: To assemble F/L (filter/lubricator) combinations, AK105FL (Combination Assembly Kit) must be used, using the joining block in the same position as the regulator.

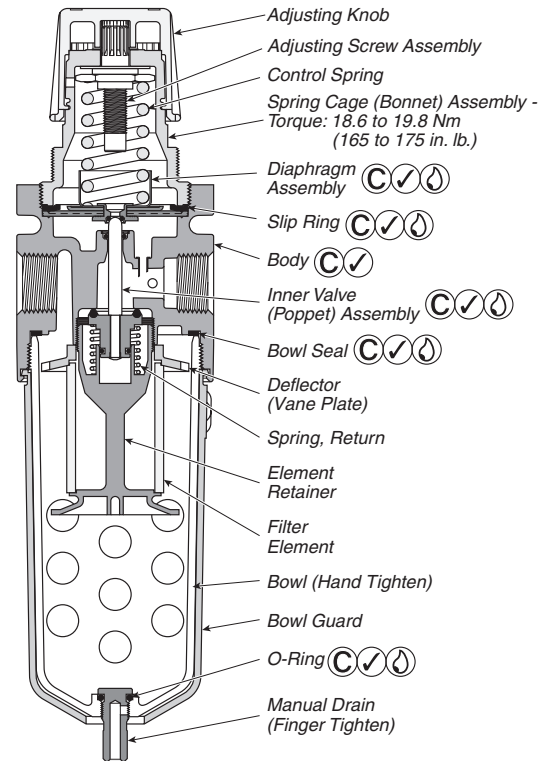

Figure 1

- Lightly grease with provided lubricant.
- Inspect for nicks, scratches, and surface imperfections.
- If present, reduced service life is probable and future replacement should be planned.
- Clean with lint-free cloth.

Service / Parts Kits Available

Description	B105 (3/8", 1/2", & 3/4")	Bowl Type
Bowl Kits*		
Polyurethane	BKF105B	B
Zinc	BKF105D	D
Zinc (with Sight Gauge)	BKF105W	W
Cage Kits	CKR105	—
Combination Assembly Kit	AK105	B, D, W
F/L Combination Assembly Kit	AK105FL	B, D, W
Filter Element (5 Micron)	EK100G	B, D, W
Filter Element (40 Micron)	EK100J	B, D, W
Filter Repair Kit (Deflector, Element Retainer)	RKF100	B, D, W
Gauge, 0 to 60 (0 to 4 bar)	K4520N14060	B, D, W
Gauge, 0 to 160 (0 to 11 bar)	K4520N14160	B, D, W
Gauge, 0 to 300 (0 to 21 bar)	K4520N14300	B, D, W
Panel Mount Bracket / Nut	SAR10Y57	B, D, W
Panel Mount Nut	R10X51-P	B, D, W
Wall Mount Bracket	SAR10Y57	—
Internal Auto Drain (Max. Pressure 175 PSIG)	SA602MD SAF105MD	B, D W
Regulator Repair Kit (Relieving)	RKR105	B, D, W
Regulator Repair Kit (Non-Relieving)	RKR105K	B, D, W
Adjusting Knob	R105-0542P	B, D, W
Return Spring	SPR-100	B, D, W

*Bowl kits include bowl seal and bowl guard assembly.