

 **WARNING**

To avoid unpredictable system behavior that can cause personal injury and property damage:

- Disconnect electrical supply (when necessary) before installation, servicing, or conversion.
- Disconnect air supply and depressurize all air lines connected to this product before installation, servicing, or conversion.
- Operate within the manufacturer's specified pressure, temperature, and other conditions listed in these instructions.
- Medium must be moisture-free if ambient temperature is below freezing.
- Service according to procedures listed in these instructions.
- Installation, service, and conversion of these products must be performed by knowledgeable personnel who understand how pneumatic products are to be applied.
- After installation, servicing, or conversion, air and electrical supplies (when necessary) should be connected and the product tested for proper function and leakage. If audible leakage is present, or the product does not operate properly, do not put into use.
- Warnings and specifications on the product should not be covered by paint, etc. If masking is not possible, contact your local representative for replacement labels.

With Polyurethane Bowl

	kPa	PSIG	bar
Operating Pressure Maximum	1034	150	10
Operating Temperature Range	4.4°C to 48.9°C (40°F to 120°F)		

With Zinc Bowl

	kPa	PSIG	bar
Operating Pressure Maximum	2068	300	21
Operating Temperature Range	4.4°C to 82.0°C (40°F to 180°F)		

With Zinc Bowl & Wrap Around Sight Gauge

	kPa	PSIG	bar
Operating Pressure Maximum	1723	250	17.0
Operating Temperature Range	4.4°C to 65.60°C (40°F to 150°F)		

ANSI Symbols

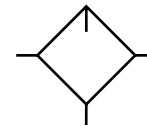

 **CAUTION**

Polyurethane bowls, sight glass and sight domes on these units may be attacked by certain chemicals. Never use solvents like carbon tetrachloride, trichlorethylene, acetone, or paint thinner to clean any parts. These elements can cause crazing or failure of the plastic parts. The polyurethane resin parts are compatible with most hydrocarbon based synthetic lubricants but, before using, check with the manufacturer of the lubricant or oil for compatibility with polyurethane resin.

TO CLEAN POLYURETHANE BOWLS USE MILD SOAP AND WATER ONLY!

 **WARNING**

FAILURE OR IMPROPER SELECTION OR IMPROPER USE OF THE PRODUCTS AND/OR SYSTEMS DESCRIBED HEREIN OR RELATED ITEMS CAN CAUSE DEATH, PERSONAL INJURY AND PROPERTY DAMAGE.

This document and other information from The Company, its subsidiaries and authorized distributors provide product and/or system options for further investigation by users having technical expertise. It is important that you analyze all aspects of your application, including consequences of any failure and review the information concerning the product or systems in the current product catalog. Due to the variety of operating conditions and applications for these products or systems, the user, through its own analysis and testing, is solely responsible for making the final selection of the products and systems and assuring that all performance, safety and warning requirements of the application are met.

The products described herein, including without limitation, product features, specifications, designs, availability and pricing, are subject to change by The Company and its subsidiaries at any time without notice.

Introduction

Follow these instructions when installing, operating, or servicing the product.

Application Limits

These products are intended for use in general purpose compressed air systems only.

EXTRA COPIES OF THESE INSTRUCTIONS ARE AVAILABLE FOR INCLUSION IN EQUIPMENT / MAINTENANCE MANUALS THAT UTILIZE THESE PRODUCTS. CONTACT YOUR LOCAL REPRESENTATIVE.

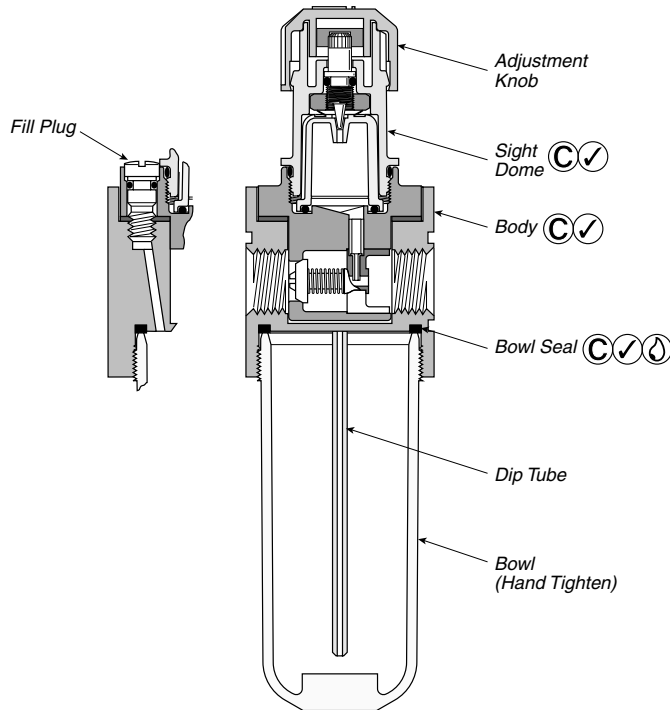

- Lightly grease with provided lubricant.
- Inspect for nicks, scratches, and surface imperfections. If present, reduced service life is probable and future replacement should be planned.
- Clean with lint-free cloth.

Installation

1. The lubricator should be installed with reasonable accessibility for service whenever possible – repair service kits are available. Keep pipe or tubing lengths to a minimum with inside clean and free of dirt and chips. Pipe joint compound should be used sparingly and applied only to the male pipe – never into the female port. Do not use PTFE tape to seal pipe joints – pieces have a tendency to break off and lodge inside the unit, possibly causing malfunction. Also, new pipe or hose should be installed between the filter and equipment being protected.
2. The upstream pipe work must be clear of accumulated dirt and liquids.
3. Select a lubricator location as close as possible to the equipment being protected and upstream of any pressure regulator.
4. Install lubricator so that air flows in the direction of arrow on body.
5. Install lubricator vertically with bowl drain mechanism at the bottom.

Operation and Service

1. Filling — The inlet pressure of the lubricator must be turned off and depressurized before the Fill Plug is removed. Turn counterclockwise to remove. Fill to within 1/4" from top of bowl or to top of the sight glass on the bowl.

Suggested lubricant: F442

Petroleum based oil of 100 to 200 SSU viscosity at 100°F and an aniline point greater than 200°F. (Mobil DTE24 and Sun Company Sunvis 932 are good examples). Do not use oils with adhesives, compound oils containing solvents, graphite, detergents or synthetic oils.

2. Replace the Fill Plug (by turning clockwise) and seat firmly. Excessive torque is not required. Turn on air supply, if leakage occurs, **DO NOT OPERATE** — conduct repairs again. The lubricator is now ready for setting.
3. Oil delivery adjustment — To adjust oil delivery, turn Adjustment Knob on top of the lubricator.

Leaner — Clockwise

Richer — Counterclockwise

By counting the number of drops per minute in the Sight Dome, you can adjust to your requirements. Generally, one drop per minute downstream for every 10 - 15 SCFM flow is satisfactory. 25 drops per minute equals one (1) ounce per hour - volume of oil passing through the Sight Dome.

NOTE: This is a constant density type lubricator which delivers a constant ratio of oil air flow. Therefore, if air flow increases or decreases, oil delivery will be adjusted proportionately. **ONLY IF A DIFFERENT RATIO IS DESIRED SHOULD YOUR ADJUSTMENT KNOB SETTING BE CHANGED AFTER YOUR INITIAL SETTING.**

4. Cleaning — Erratic lubricator operation or loss of lubrication is almost always due to dirt (rust, pipe tape, etc.) in the needle valve or venturi area. To clean, shut off and vent all air line pressure to the unit being cleaned. In most cases cleaning is needed only in the oil metering area. Pull off Adjusting Knob and remove Sight Dome Assembly. Make sure hole in Body Seat and Drip Spout is clear. Remove Bowl. Clean parts with soapy water or denatured alcohol **but do not use denatured alcohol on plastic bowl, sight dome or sight gauge.** If using compressed air to blow dry, be sure to wear appropriate eye protection.
5. After servicing, apply system pressure and check for air leaks. If leakage occurs, **Do Not Operate** — conduct servicing again.

Kits Available

Description	Product Number	Bowl Type
Bowl		
Polyurethane	BKL35A	A
Zinc	BKF35D	D
Zinc with Wrap		
Around Sight Gauge	BKL35W	W
Repair Kit		
Tamper-resistant	RKL100	A, D, W
Sight Dome Repair Kit		
Adjusting Knob	L100-0726P	—
Dip Tube	L30-0741	—
Bowl Seal	GSK-504Z101	A, D, W