

 **WARNING**

To avoid unpredictable system behavior that can cause personal injury and property damage:

- Disconnect electrical supply (when necessary) before installation, servicing, or conversion.
- Disconnect air supply and depressurize all air lines connected to this product before installation, servicing, or conversion.
- Operate within the manufacturer's specified pressure, temperature, and other conditions listed in these instructions.
- Medium must be moisture-free if ambient temperature is below freezing.
- Service according to procedures listed in these instructions.
- Installation, service, and conversion of these products must be performed by knowledgeable personnel who understand how pneumatic products are to be applied.
- After installation, servicing, or conversion, air and electrical supplies (when necessary) should be connected and the product tested for proper function and leakage. If audible leakage is present, or the product does not operate properly, do not put into use.
- Warnings and specifications on the product should not be covered by paint, etc. If masking is not possible, contact your local representative for replacement labels.

Introduction

Follow these instructions when installing, operating, or servicing the product.

Application Limits

These products are intended for use in general purpose compressed media systems only.

Operating Pressure:

	kPa	PSIG	bar
Maximum Inlet Pressure	2068	300	21.0

Ambient Temperature Range: 4°C to 49°C
 (40°F to 120°F)

 **WARNING**

Product rupture can cause serious injury.
Do not connect regulator to bottled gas.
Do not exceed maximum primary pressure rating.

ANSI Symbols

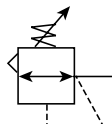

Installation

Installation of the R119-J requires the use of an additional pilot regulator to control the reduced pressure output of the R119-J unit. A typical installation is shown on reverse side, where a Type R119, R10 or R384 regulator is used to furnish the pilot operating supply pressure. With the flexibility provided by this typical installation, the R119-J regulator may be used in a remote and inaccessible location while the pilot regulator can be placed in a convenient location to control operation of the R119-J regulator.

Either a rigid pipe or flexible tubing may be utilized to connect the R119-J unit to the pilot regulator.

Before installing, blow out pipe line to remove scale and other foreign matter. This unit has DRYSEAL pipe threads. Use pipe compound or tape sparingly to male threads only. Install regulator in pipe line so that air will flow from IN to OUT. Install as near as possible to equipment being supplied.

Connections R and L are normally for gauge use, but may be used for outlet purposes in certain applications. To ensure trouble-free performance, a filter (Type F602) should be installed upstream of the regulator.

Adjustment

Since the reduced or regulated pressure is controlled by the pilot regulator, an increase in pilot pressure into the R119-J unit will produce a corresponding increase in the regulated pressure from the R119-J regulator. All R119-J series regulators (excluding models with X71 option) are of the constant bleed design. The system pressure is internally "bled-off" permitting adjustment for lower reduced pressure settings without the necessity of waiting for the flow to start.

NOTE: A small internal constant bleed device permits accurate fine point setting capability. This constant air bleed may be audible and is a perfectly normal characteristic of the regulator.

Maintenance

If the main supply or pilot air supply are kept clean, the regulator should provide long periods of uninterrupted service. Erratic regulator operation, or loss of regulation, is most always due to dirt accumulating in the disc area. To remedy, clean the regulator as outlined below.

Cleaning

Depressurize, remove bottom plug, spring and disc. Clean parts with alcohol, wipe off seat and blow out body with compressed air. Reassemble parts as a unit and screw into regulator (disc bottom O-ring must be relubed prior to assembly). Before tightening bottom plug, make sure disc is in center hole in body.

See reverse side for Service Kits / Parts Available.

 **WARNING**

FAILURE OR IMPROPER SELECTION OR IMPROPER USE OF THE PRODUCTS AND/OR SYSTEMS DESCRIBED HEREIN OR RELATED ITEMS CAN CAUSE DEATH, PERSONAL INJURY AND PROPERTY DAMAGE.

This document and other information from The Company, its subsidiaries and authorized distributors provide product and/or system options for further investigation by users having technical expertise. It is important that you analyze all aspects of your application, including consequences of any failure and review the information concerning the product or systems in the current product catalog. Due to the variety of operating conditions and applications for these products or systems, the user, through its own analysis and testing, is solely responsible for making the final selection of the products and systems and assuring that all performance, safety and warning requirements of the application are met.

The products described herein, including without limitation, product features, specifications, designs, availability and pricing, are subject to change by The Company and its subsidiaries at any time without notice.

EXTRA COPIES OF THESE INSTRUCTIONS ARE AVAILABLE FOR INCLUSION IN EQUIPMENT / MAINTENANCE MANUALS THAT UTILIZE THESE PRODUCTS. CONTACT YOUR LOCAL REPRESENTATIVE.

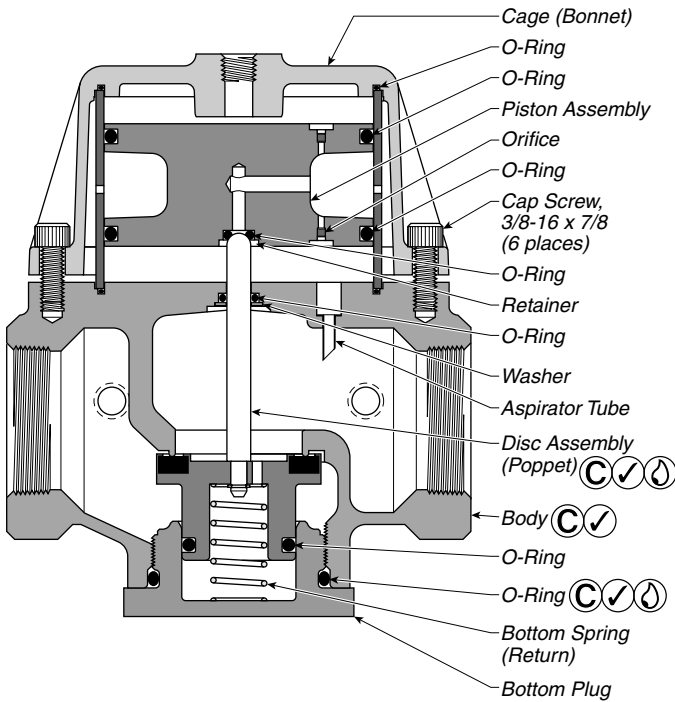
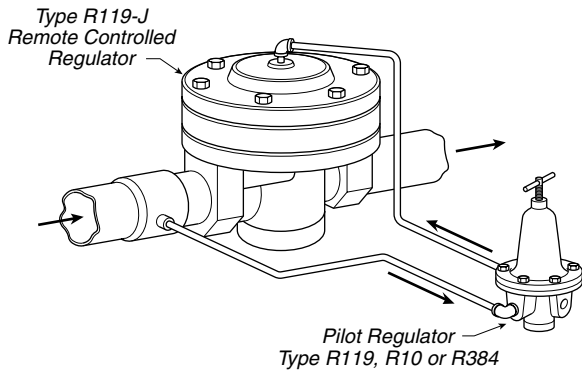

- ☉ Lightly grease with provided lubricant.
- ☑ Inspect for nicks, scratches, and surface imperfections. If present, reduced service life is probable and future replacement should be planned.
- Ⓒ Clean with lint-free cloth.

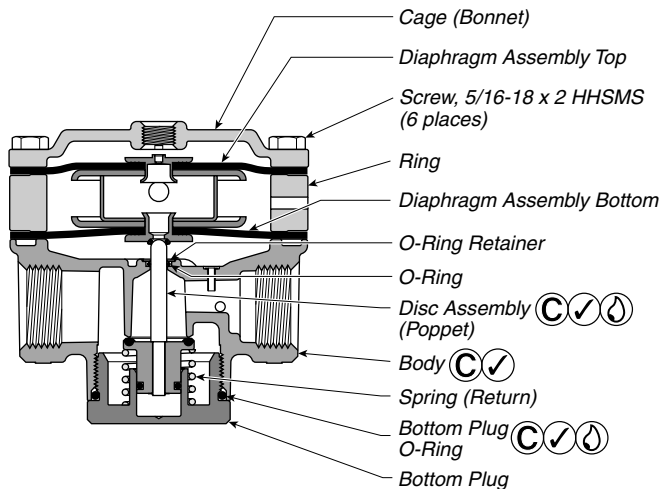

Service Kits / Parts Available

Description	Kit Number	Regulator Size
Regulator Repair Kit (Relieving) Includes: Diaphragm Assembly Top, Diaphragm Assembly Bottom, Disc Assembly, Bottom Plug Gasket	RK119X20Y RK119X20A RK119X20B RK119X20D	1/4", 3/8" 1/2" 3/4", 1" 1-1/4", 1-1/2"
Regulator Repair Kit (Non-Relieving) Includes: Diaphragm Assembly Top, Diaphragm Assembly Bottom, Disc Assembly, Bottom Plug Gasket	RK118X20Y RK118X20A RK118X20B RK118X20D	1/4", 3/8" 1/2" 3/4", 1" 1-1/4", 1-1/2"
2-1/2" Regulator Repair Kit Includes: Piston O-Rings, Cylinder O-Rings, Disc Assembly, Strainer, Bottom Plug Gasket	RK119G	2-1/2"

Accessories

Gauges	
0 to 60 PSI (0 to 4 bar)	K4520N14060
0 to 160 PSI (0 to 11 bar)	K4520N14160
0 to 300 PSI (0 to 20 bar)	K4520N14300

Suggested Installation or Mounting for the 2" and 2-1/2" R119-16 and 20J

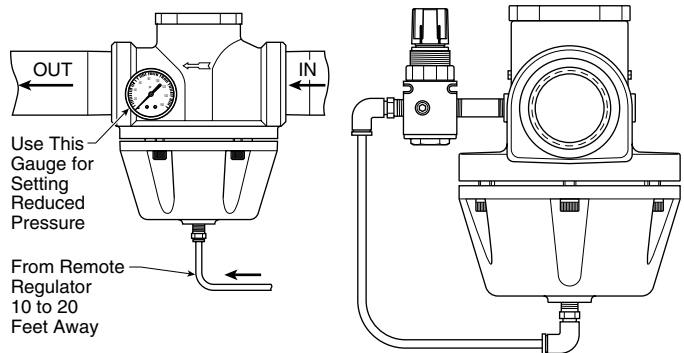

1. The top two are the best way of mounting for all applications.
2. For best results at low pressure, mount inverted as shown above.
3. Use a precision regulator, R216, R230, or R210 for low pressure.

